



ROPEGUIDE TWINLINE



- **DE** Das vorliegende Produkt darf nur dann benutzt werden, wenn diese Bedienungsanleitung sprachlich verstanden werden kann.
- **EN** This product may only be used if the language of the User Manual can be understood.
- **FR** Le présent produit peut être utilisé uniquement s'il est possible de comprendre les indications figurant dans le mode d'emploi.
- **ES** Este producto sólo deberá ser usado si se entiende el idioma de las instrucciones de uso.
- **IT** Il presente prodotto può essere utilizzato solo se le istruzioni di esercizio siano state comprese dal punto di vista linguistico.
- **PT** Este produto só deve ser usado se a língua das instruções de uso é entendida.
- **NL** Dit product mag alleen gebruikt worden wanneer de bedieningshandleiding qua taal begrepen kan worden.
- **SE** Denna produkt får endast användas om språket i bruksanvisningen kan förstås.
- **FI** Tämän tuotteen käyttö on sallittu vain, kun käyttäjä ymmärtää käyttöohjeen kielen.
- **NO** Dette produktet må kun anvendes dersom språket i bruksanvisningen kan forstås.
- **DK** Dette produkt må kun bruges, hvis sproget i brugsanvisningen kan forstås.
- **CZ** Pøedložený výrobek lze používat pouze tehdy, když lze z jazykového hlediska porozumět návodu k obsluze.
- **PL** Użytkowanie tego produktu jest dozwolone wyłącznie pod warunkiem, że język instrukcji obsługi jest rozumiany.
- **SK** Predložený výrobok je možné používať len vtedy, pokiaľ je z jazykového hľadiska možné porozumieť návodu na obsluhu.
- **HU** A termékét csak akkor használja, ha megértette a kezelési utasítás értelmét.
- **RU** Настоящий продукт может использоваться только в том случае, если понятен язык руководства по эксплуатации.

Hubert Kowalewski e.K.
In den Sennen 19
D-32369 Rahden-Wehe



Telefon +49 5771 608783
Telefax +49 5771 608782
www.climb-ART.com

- DE** Erforderliche Schutzausrüstung (PSA)
- EN** Required personal protection equipment (PPE)
- FR** Equipment personnel de protection nécessaire (EPP)
- ES** Equipo de protección individual necesario (EPI)
- IT** Dotazione protettiva personale obbligatorio (DPP)



Legende / Legend:



- DE Absturzgefahr
- EN Danger of falling
- FR Risque de chute
- ES ¡Peligro de caída
- IT Pericolo di caduta



- DE Achtung
- EN Caution
- FR Attention
- ES ¡Atención
- IT Attenzione



- DE Weitere Infos beachten
- EN Heed further information
- FR Observer les autres informations
- ES ¡Obsérvense otras informaciones
- IT Fare attenzione ad ulteriori info



- DE Durchlaufsicherung beachten
- EN Pa attention to throughrunning safety straps
- FR Veiller à un dispositif de protection au coup par coup
- ES ¡Prestar atención al seguro de deslizamiento
- IT Fare attenzione alla sicurezza passante



- DE Falsch
- EN Wrong
- FR Faux
- ES ¡Incorrecto
- IT Errato



- DE Beachten / Kontrollieren
- EN Note / check
- FR A observer / a contrôler
- ES ¡Observar / controlar
- IT Fare attenzione / Controllare



- DE Kurzsicherung anlegen
- EN Attach short safety straps
- FR Porter une corde à mousquetons courte
- ES ¡Fijar seguro corto
- IT Applicare fune autobloccante



- DE Angaben zum Seil beachten
- EN Follow details of the rope
- FR Respecter le informations de câble/corde
- ES ¡Obsérvese el datos de la cuerda
- IT Fare attenzione al dati della fune



- DE Drehmoment beachten
- EN Heed torque
- FR Respecter le couple
- ES ¡Obsérvese el par de giro
- IT Fare attenzione alla coppia di serraggio



- DE Belastbarer Ankerpunkt
- EN Use robust anchor point
- FR Utiliser un point d'ancrage résistant
- ES ¡Utilícese un punto de anclaje que soporte carga
- IT Utilizzare punto di ancoraggio caricabile

Legende / Legend:



- DE Mindestbruchlast
- EN Minimum breaking load
- FR Charge minimale à la rupture
- ES ¡Carga mínima de rotura
- IT Carico di rottura minimo



- DE Maximale Arbeitslast
- EN Maximum working load
- FR Charge de travail maximale
- ES ¡Carga máxima de trabajo
- IT Carico di lavoro massimo



- DE Geprüfte Testlast
- EN Certified testload
- FR Charge certifiées
- ES Prova die carico certificato
- IT Test de carga certificado



- DE Richtig / In Ordnung
- EN Correct / O.K.
- FR Correct / En ordre
- ES ¡Correcto / en orden
- IT Corretto / OK

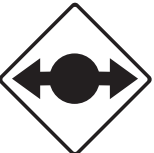

- DE Oder
- EN Or
- FR Ou
- ES O
- IT O



- DE Doppel-Seil-Technik
- EN Double rope technique
- FR Travaille corde à double / technique classique
- ES Técnica de cuerda doblo drt
- IT Tecnica della corda doppia



- DE Stehend-Seil-Technik
- EN Single rope technique / stationary rope technique
- FR Travaille sur corde en simple brin
- ES Técnica de cuerda simple / SRT
- IT Tecnica della corda singolar / SRT



- DE Aufstieg
- EN Ascent
- FR Ascension
- ES Ascenso
- IT Risalita / Salita



- DE Aufstieg
- EN Ascent
- FR Ascension
- ES Ascenso !
- IT Risalita / Salita

Legende / Legend:



- DE Knoten festziehen
- EN Tighten the knot
- FR Serrer le noeud
- ES Tensar el nudo
- IT Serrare il nodo



- DE Schmetterling
- EN Butterfly
- FR Papillon
- ES Mariposa
- IT Farfalla



- DE Stamm-Anker mit abziehbarer Fixierung
- EN Trunk anchor with removable fixing
- FR Ancrage au tronc avec fixation amovible
- ES Anclaje en tronco con fijación desmontable
- IT Ancoraggio basale con fissaggio rimovibile



- DE Stamm-Anker mit fixiertem Seil
- EN Trunk anchor with fixed rope
- FR Ancrage au tronc avec corde fixe
- ES Anclaje en tronco con cuerda fija
- IT Ancoraggio basale con corda fissata



- DE Isolierter Ankerpunkt
- EN Isolated anchor point
- FR Point d'ancrage isolé
- ES Punto de anclaje aislado
- IT Punto di ancoraggio isolato

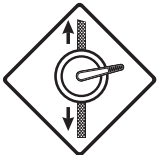

- DE Abseilgerät
- EN Descender
- FR Descendeur
- ES Descensor
- IT Discensore

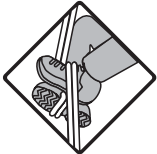

- DE Footlock
- EN Footlock
- FR Footlock
- ES Footlock
- IT Footlock



- DE Seil fixieren
- EN Fix the rope
- FR Fixer la corde
- ES Fijar la cuerda
- IT Fissare la corda

Legende / Legend:

CE 0123

- DE Organisation, welche die Herstellung dieser PSA kontrolliert
- EN Body controlling the manufacturing of this PPE
- FR Organisme controlant la fabrication de cet EPI
- ES Organismo controlador de la fabricación
- IT Organismo che controlla la fabbricazione

21.16 01 001

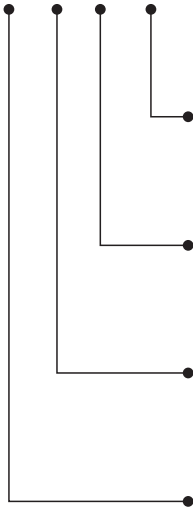

- DE Individuelle Nummer
- EN Individual number
- FR Numéro individuel
- ES Numero individual
- IT Numero individuale

- DE Serie
- EN Batch
- FR Série
- ES Serie
- IT Serie

- DE Herstellungsjahr
- EN Year of manufacture
- FR Année de fabrication
- ES Año de fabricación
- IT Anno di fabbricazione

- DE ART Code
- EN ART Code
- FR Code ART
- ES Código de ART
- IT Codice di ART

PSA

- DE PSA (Persönliche Schutzausrüstung)
- EN PPE (Personal Protective Equipment)
- FR EPI (équipement personnel de protection)
- ES EPI (Equipo de protección individual)
- IT DPP (Dotazione protettiva personale)

EN ...

- DE Anforderung
- EN Requirement
- FR Exigence
- ES Exigencia
- IT Requisiti



Erläuterungen zum Bildanhang:

H

RopeGuide TwinLine mit langem Ankerseil

SRT Ausbau

Seite 123 bis Seite 128



I

RopeGuide TwinLine mit langem Ankerseil

SRT / DRT und Zwei-Personen-Anwendung /
-Rettung

Seite 129 bis Seite 132

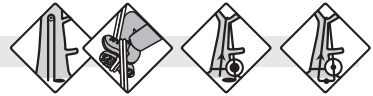

J

RopeGuide TwinLine mit kurzem Ankerseil

ART SpliceAnchor Einbau und Anwendung

Seite 133 bis Seite 135

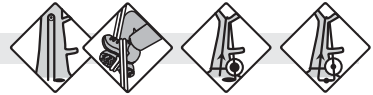

K

RopeGuide TwinLine mit kurzem Ankerseil

ART SpliceAnchor Ausbau

Seite 137 bis Seite 138

L

RopeGuide TwinLine mit langem Ankerseil

Umbau zum kurzen Ankerseil:

ART SpliceAnchor

Seite 139 bis Seite 141



M

RopeGuide TwinLine

Aufstieg mit Stamm-Anker
und separatem Zustiegsseil

Seite 143 bis Seite 146



N

RopeGuide TwinLine

Gefährliche Fehler

Seite 147 bis Seite 150



ROPEGUIDE TWINLINE

Patented

EN

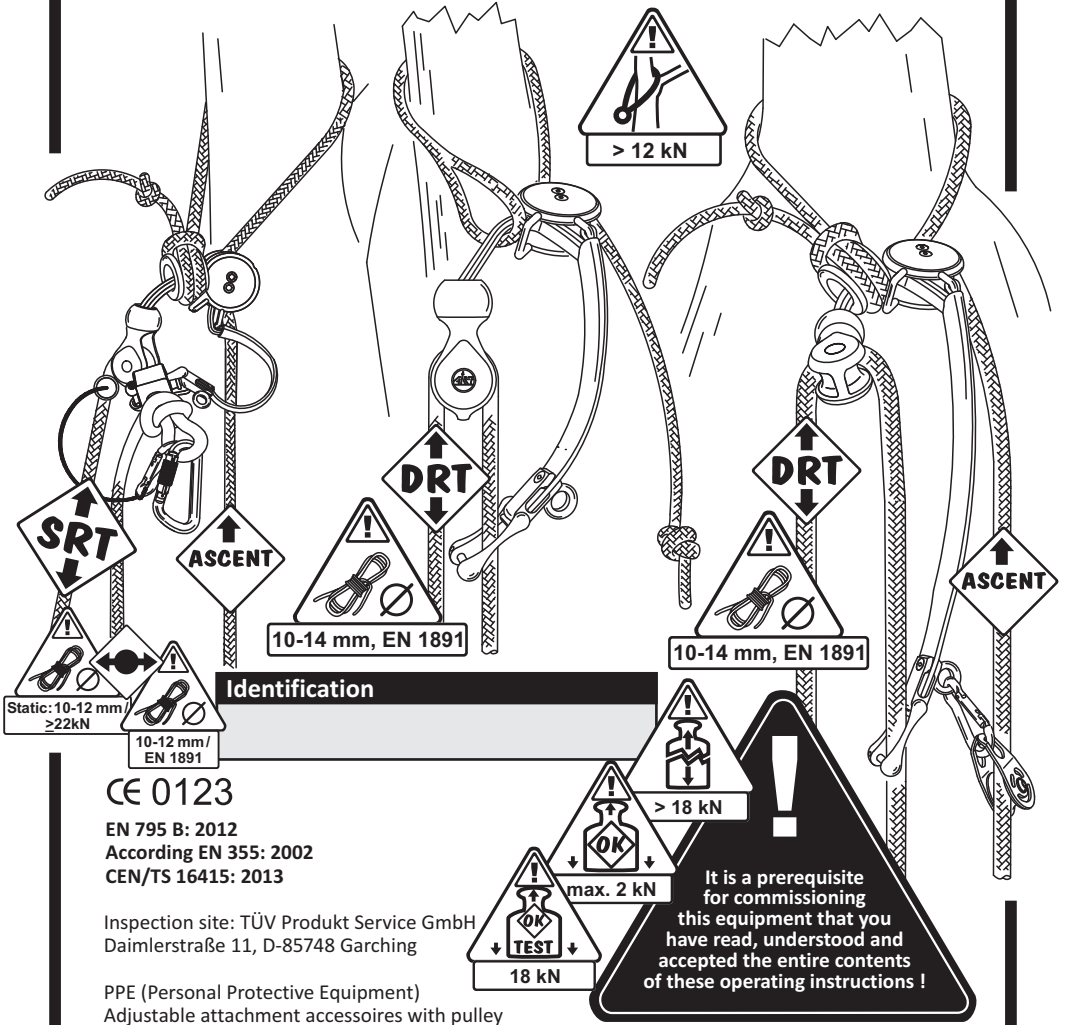

Identification

CE 0123

EN 795 B: 2012
According EN 355: 2002
CEN/TS 16415: 2013

Inspection site: TÜV Produkt Service GmbH
Daimlerstraße 11, D-85748 Garching

PPE (Personal Protective Equipment)
Adjustable attachment accessories with pulley

Hubert Kowalewski e.K.
In den Sennen 19
D-32369 Rahden-Wehe



Telefon +49 5771 608783
Telefax +49 5771 608782
www.climb-ART.com

RopeGuide TwinLine, with long anchor rope:

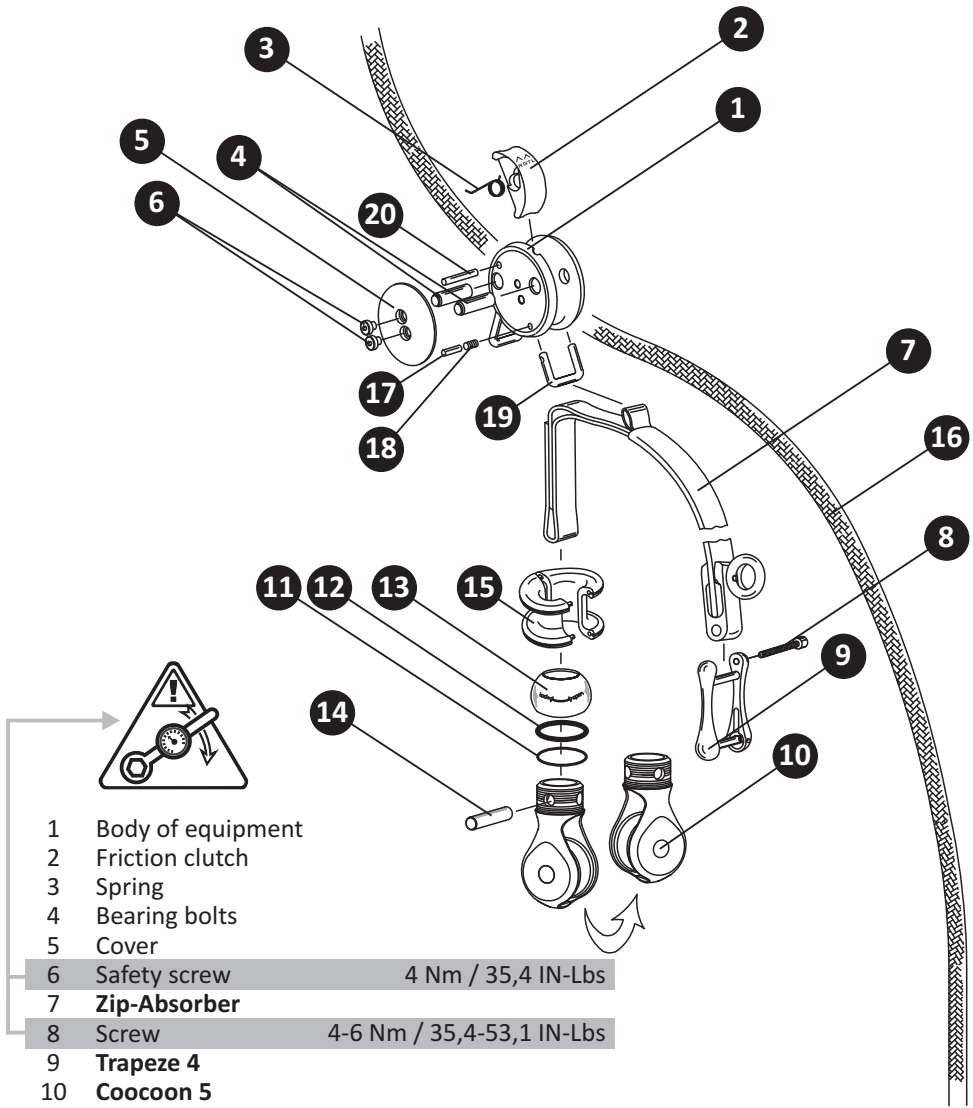

- 1 Body of equipment
- 2 Friction clutch
- 3 Spring
- 4 Bearing bolts
- 5 Cover
- 6 Safety screw
- 7 **Zip-Absorber**
- 8 Screw
- 9 **Trapeze 4**
- 10 **Cocoon 5**
- 11 O-Ring, red
- 12 O-Ring, black
- 13 Screw cap
- 14 Bearing bolts
- 15 **SliderSpool**

16 Anchor rope Reference: GeoStatic 10,5 / 11 mm, Gleistein Ropes, Germany

- 17 Dowel pin
- 18 Spring
- 19 Bow
- 20 Dowel pin

RopeGuide TwinLine, with SpliceAnchor:

EN

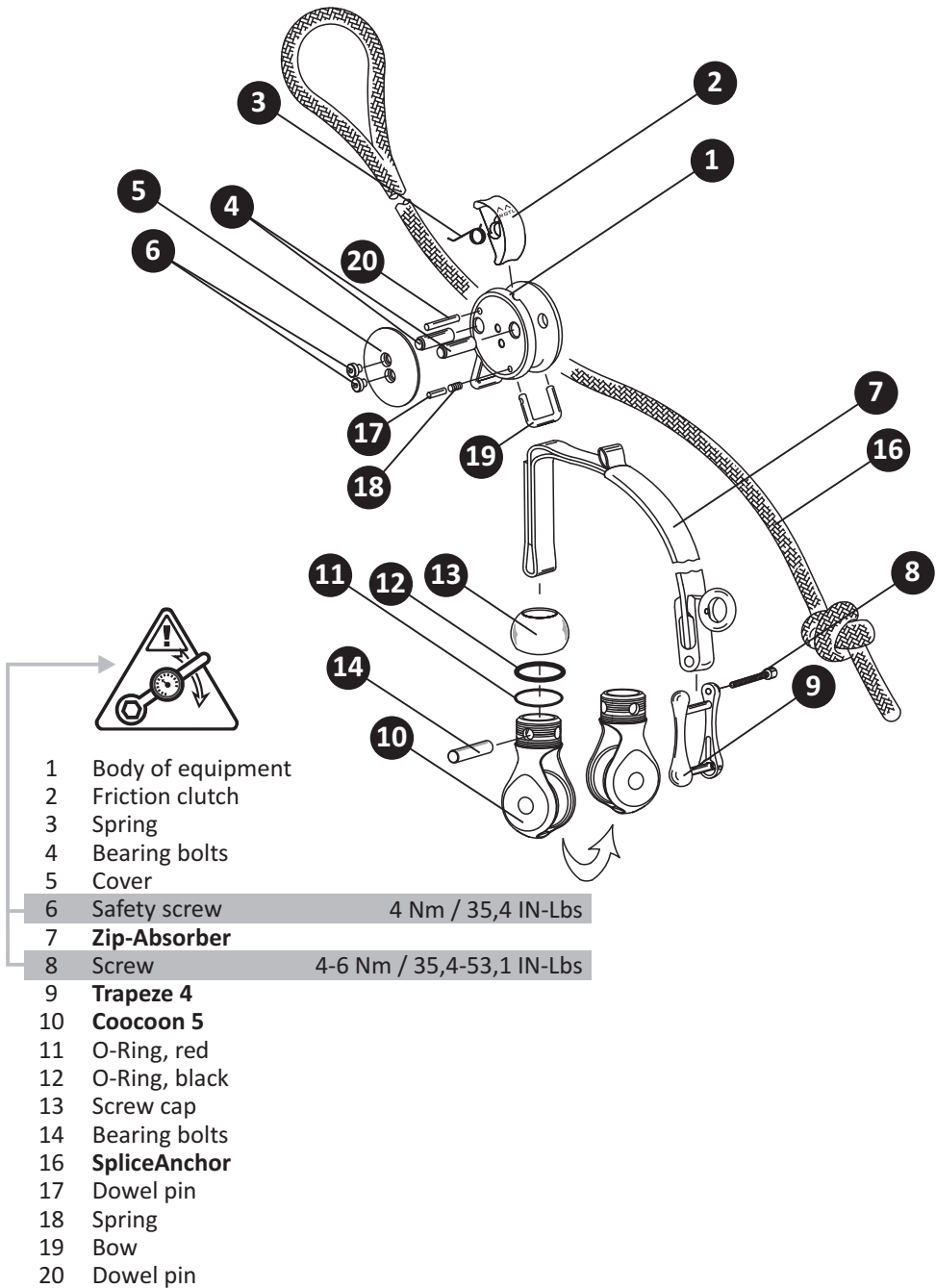

Liability exclusion

Hubert Kowalewski e.K. does not assume any responsibility or liability in the case of:

- damage arising in any way in connection with the application of ART products.
- slight, serious and lethal injury of the user or persons indirectly or directly involved in the occurrence which can be in any way attributed to non-compliance with these operating instructions.

Basic instructions

The user of this device must provide evidence that recognised training in tree climbing has been completed.

The fundamental rule applies that all activities performed at a height are dangerous and can result in serious injury or even death if the specified safety regulations are disregarded or in the case of any other kind of incorrect use.

The equipment before you only guarantees the highest levels of safety in association with the requisite knowledge and techniques with respect to every action at a height or depth, and assuming precise compliance with these operating instructions.

You may only use this product if you are prepared to undergo appropriate instruction, training, application, inspection and maintenance of the equipment at your own responsibility in accordance with the specifications of the manufacturer.

Since the quality and intensity of instruction and individual practical experience varies considerably in the areas of tree climbing and rope climbing technology, the following rule specified by the manufacturer for this equipment must be complied with:

The user of this equipment must ensure at his own responsibility that safe training is carried out with the new equipment. The objective must be to unambiguously understand the functions, correct usage, the correct maintenance, the possible operating errors and the limits of this equipment, and to be proficient in their practical use.

Safe practising with specialised equipment from ART always starts on ground which is safe and, where possible, not too hard.

Every user may only dispense with additional safety measures, such as redundant safeguarding or a qualified safety person, if absolutely no further safety concerns exist.

On the other hand training and advice from an experienced instructor, with ART experience if possible, should always be sought where doubt exists with respect to own proficiency.

This equipment may only be used to secure people, and the respective equipment may only be assigned to the person documented who is responsible for it.

In addition to the abovementioned prerequisites, the user must be physically and mentally healthy and his sense of awareness must not be impaired in any way. In particular alcohol, drugs and medication can lead to life threatening operating errors.

Every user must fundamentally know and accept that any period spent at height or at a depth requires permanent attention and care. ART products guarantee functionality, efficiency and safety when used correctly. ART products may fundamentally only be used in accordance with the manufacturer's specifications.

The safe use of special equipment for securing ropes involves interaction between the equipment provided, correct use following instruction and training as well as constant maintenance and inspection of the entire equipment.

Care must always be taken when deploying rope securing equipment that suitable body protection is used. Here a helmet, protective goggles, gloves, shoes, protection against cutting, ear protection and clothes must comply with the valid regulations.

Service life

If this equipment is used as intended the service life of metal elements under consideration of all manufacturing information is a maximum of 10 years after using for the first time. The maximum service life of textile elements (insofar as these exist) is 5 years.

In the case of unfavourable stress it is possible for the equipment or individual elements to also be unusable after a single operation (e.g. where there is deformation of metal parts through hard knocking from a great height or damage to the fibre structure of a textile element through massive friction or cutting or tearing elements).

It must additionally be noted that rope securing equipment also experiences aging and wear when correctly used. This applies in particular to textile components. After severe stress (fall) or a hard knock to this equipment (e.g. against asphalt, rocks, metal) the entire equipment subjected to the stress must be taken out of use and must undergo a precise inspection as follows:

- a device which exhibits deformation, pitting or even tears must be taken out of use immediately and subjected to careful inspection by a person authorised in writing to undertake this (information: www.Climb-art.com) or should be disposed of such that renewed use can be excluded;
- the renewal of the body of the equipment and installation of non-damaged or new components is permissible taking the respective assembly instructions into account;
- the equipment may only be deployed again following a concluding functional check;
- all components associated with severe stress usage, such as ropes, lanyards, belt, connecting elements and anchoring systems, must be inspected or renewed in accordance with the respective manufacturer specifications.

ART component design

Since the essential parts of ART devices are replaceable, the user can renew damaged or worn elements. The precise position, name and attachment can be taken from the exploded assembly drawing and the description attached to the respective spare part. Every replacement of device components must be documented. When components are reused

the service life identification (year of manufacture) must be heeded.

Components which comprise several individual parts, but which are depicted as a whole in the exploded assembly drawing, may not be disassembled by the user. Screw connections provided with a coloured seal may not be unscrewed by the user.

If the equipment begins to slip in the blocked position, the friction clutch must be replaced.

If the device slips in spite of the new friction clutch, the counterpart must also be replaced.

If doubts nevertheless remain about the perfect state of the equipment, these must be referred immediately to Hubert Kowalewski e.K. or to one of the sites it has authorised in writing.

Warranty

Hubert Kowalewski e.K. issues a warranty for manufacturing, functional and material faults for a period of 2 years. This warranty, however, excludes all normal wear and tear through use, oxidation and manipulation, as well as all damage which can be attributed to the effects of impact, accidents and errors which have occurred during servicing, overhauling, storage, transportation and application.

Inspection

This equipment may only be deployed if it is in perfect condition.

The functionality of this equipment must be checked by the user from a safety point of view before and after every application. It is also important that no blind trust in the entire safety-relevant equipment creeps in during deployment. Severe strain or any kind of unusual occurrence may impair the faultless functioning of any kind of equipment.

This instruction manual contains a page with control data as well as a page for documenting the inspection to be conducted at least once a year by a technical expert. The information required for correct assessment of this equipment must be consistently entered during the entire service life of the device.

Inspection criteria for the user and technical expert

- This device must be complete in accordance with the exploded assembly drawing;
- all screw connections must be complete and screwed tightly;
- all moving parts must be freely movable;
- all metal parts must be free from deformation, cracks and other damage;
- all textile components must be free from tears, cuts as well as contamination or abrasions which permeate the structure.
- Wear and tear limits of replaceable parts must be checked.

Servicing

This equipment does not require any particular servicing. It should, however, always be cleaned thoroughly after use and dried if necessary in order to avoid dirt and dust deposits, particularly on the moving parts, and to prevent corrosion.

The ART recommendation:

Cleaning and oiling the metal components, in particular the moving parts and their bearings, using neutral oil such as Ballistol ensures smooth-running functionality and a lasting good appearance.

Local safety assessment

A safety assessment must be performed of the climbing object and its surroundings before deploying this device and the entire equipment. Any hazards determined must be consistently eliminated.

All factors required for any necessary rescue action must be determined:

- special features at the location;
- telephones available for an emergency call;
- local regulations and designations as well as access paths;
- qualifications and knowledge of the climbing team in the areas of climbing techniques, operational procedures, rescue and first aid;
- presence and availability of necessary equipment and technology;
- at least one second trained climber must be visible and within earshot at all times.

Climatic factors

All ART equipment may only be deployed at ambient temperatures of -30° C to +40°C. This applies for reasons of personal protection alone.

Care must be taken in particular during frost that all movable metal parts (e.g. clamping mechanism) remain free from ice and snow.

Under some circumstances repeated functional tests may be necessary.

Every climbing action must be analysed critically in the case of special weather conditions such as heavy rainfall, strong wind or approaching storms, and should be abandoned if necessary.

Especially:

The shock absorber (ZIP-Absorber) of a Ropeguide TwinLine reduces the shock-load of a vertical fall (factor 1) of 1 meter with a weight of 100 kg to below 6 kN, also in using with static ropes.

Caution

The shock absorption serves to increase passive safety and may under no account lead to the assumption that it produces a guarantee of injury-free falls. For example, obstructions in the fall area as well as an unfavourable body posture when the fall is intercepted may precipitate considerable injuries.

Warning

No energy absorbing lanyard is released in the case of oscillating falls on a taut rope. This device fundamentally serves personal protection only.

The attachment point (tree, part of a building, girder, scaffolding etc.) for the rope system must demonstrate a minimum load capacity of 12 kN. Following professional ascension and application of a correct short safety line the attachment device must be placed such that it is permanently positioned above the climber. Climbing must also take place with a taut rope in order to minimise the risk of free falls.

Contamination/storage

If soiled, all parts of this equipment can be cleaned at temperatures of up to 40° C using water and a neutral soap. After washing all textile components (insofar as these exist) must be carefully rinsed with clear water. This device should be hung up to dry in a shaded and well ventilated place. The equipment may not be dried on heated surfaces such as radiators or near a fire. Contamination of the metal parts from tree resin can best be removed by rubbing with butter.

This device must not be exposed to any damaging influences like sources of heat above 55°C, fire, flying sparks, caustic substances, acids (car batteries and their fumes), fuels, oils etc., during use, transportation or storage. Care must be taken that there is suitable packaging during transportation (bag).



Explanation of the picture appendix:

- A** **RopeGuide TwinLine with long anchor rope**
Installing and using
Page 63 to page 70



- B** **RopeGuide TwinLine with long anchor rope**
Variations
Page 71



- C** **RopeGuide TwinLine with long anchor rope**
Removal
Page 73 to page 76

- D** **RopeGuide TwinLine with long anchor rope and separate access rope**
Installing and using
Page 77 to page 87



- E** **RopeGuide TwinLine with long anchor rope and removable, separate access rope**
Installing and using
Page 89 to page 101



- F** **RopeGuide TwinLine with long anchor rope, Changing of anchor point**
Using
Page 103 to page 114



- G** **RopeGuide TwinLine with long anchor rope SRT** Installing and using
Page 115 to page 122





Explanation of the picture appendix:

H

RopeGuide TwinLine with long anchor rope
SRT removal
Page 123 to page 128



I

RopeGuide TwinLine with long anchor rope
SRT / DRT and two-persons-using /
-rescuing
Page 129 to page 132



J

RopeGuide TwinLine with short anchor rope
ART SpliceAnchor installing and using
Page 133 to page 135

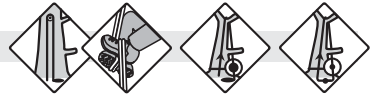

K

RopeGuide TwinLine with short anchor rope
ART SpliceAnchor removal
Page 137 to page 138

L

RopeGuide TwinLine with long anchor rope
Conversion to short anchor rope:
ART SpliceAnchor
Page 139 to page 141



M

RopeGuide TwinLine
Access with trunk anchor
and separate access rope
Page 143 to page 146



N

RopeGuide TwinLine
Hazardous mistakes
Page 147 to page 150



For The **ART** Of Treeclimbing

RopeGuide TwinLine:

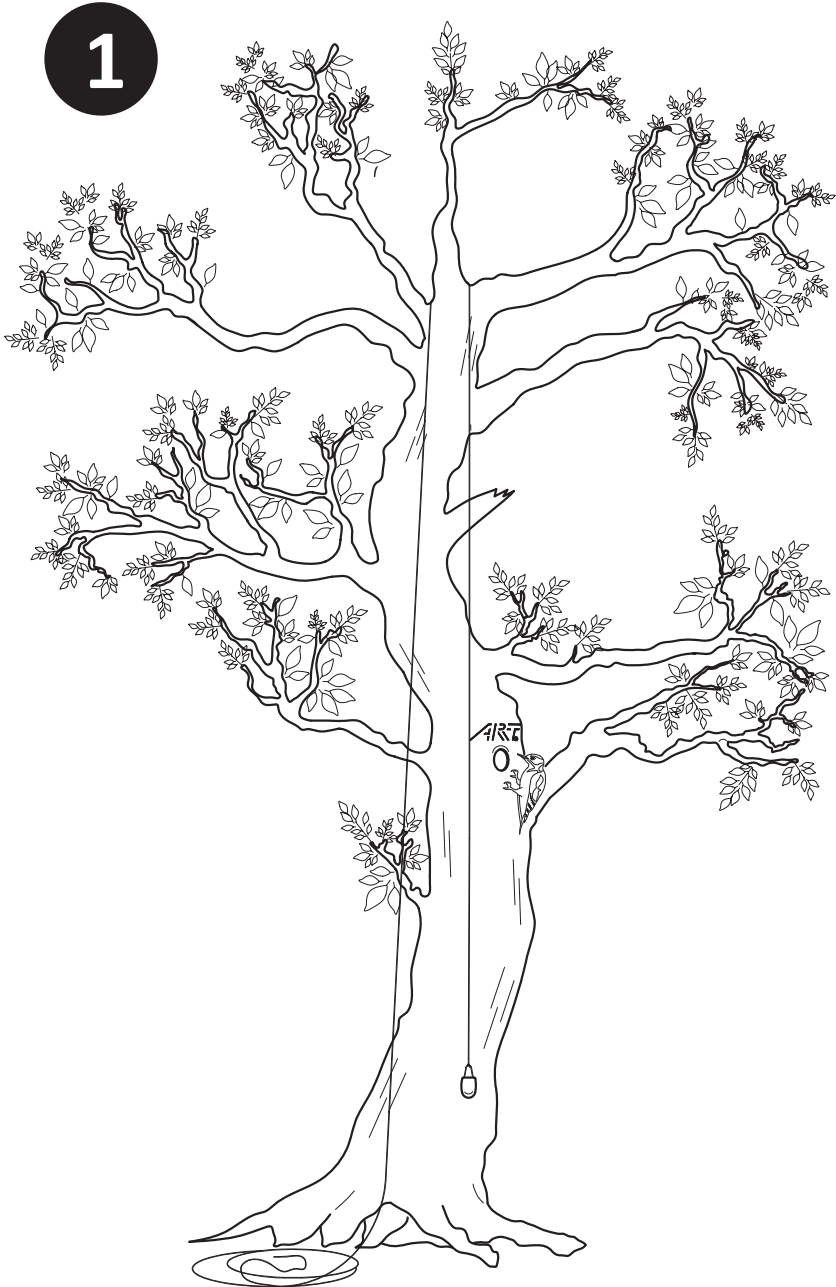

RopeGuide TwinLine:

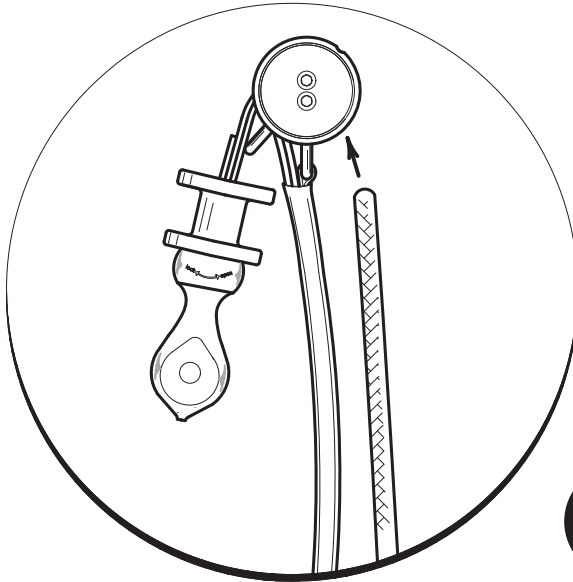

2

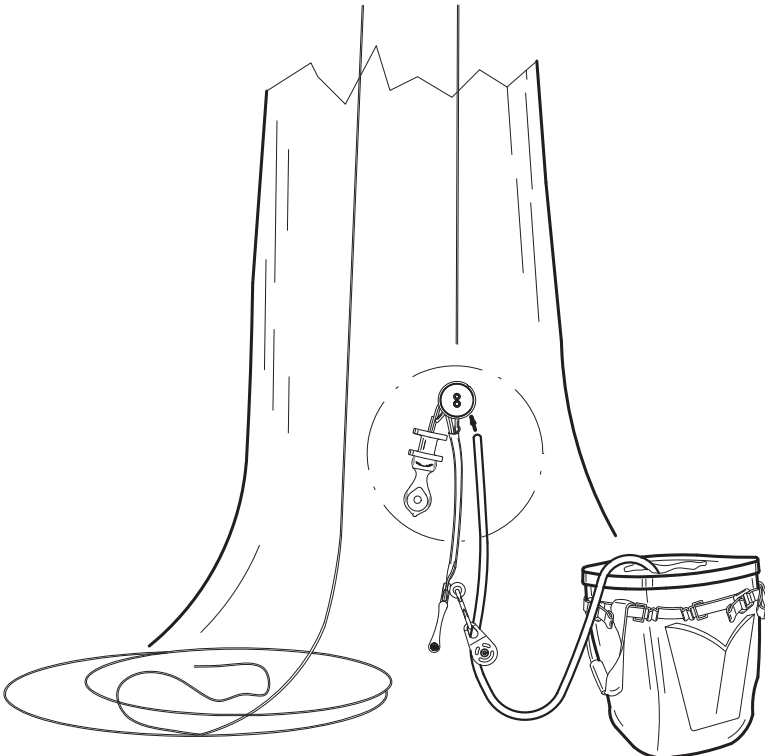

RopeGuide TwinLine:

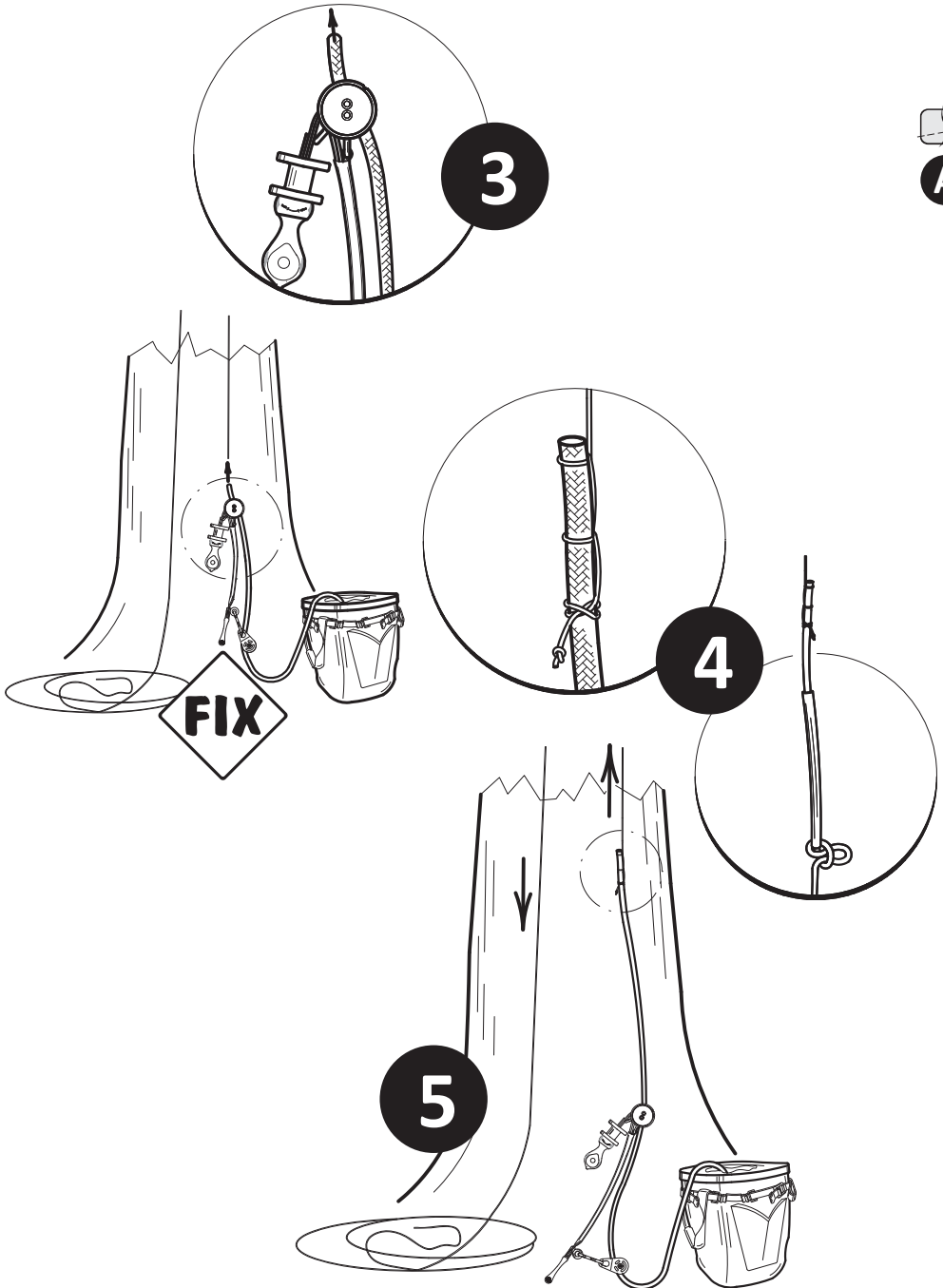

RopeGuide TwinLine:

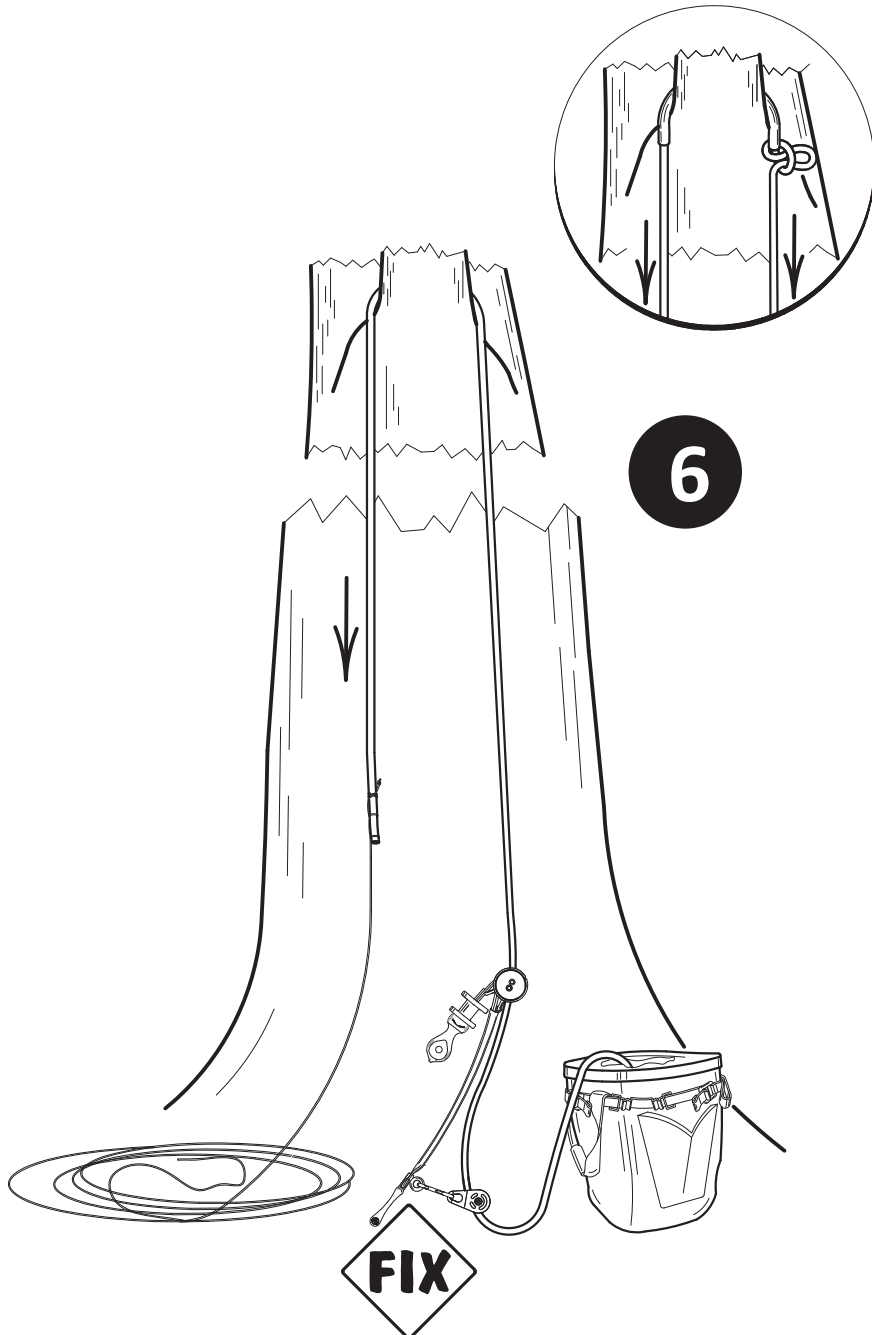

RopeGuide TwinLine:

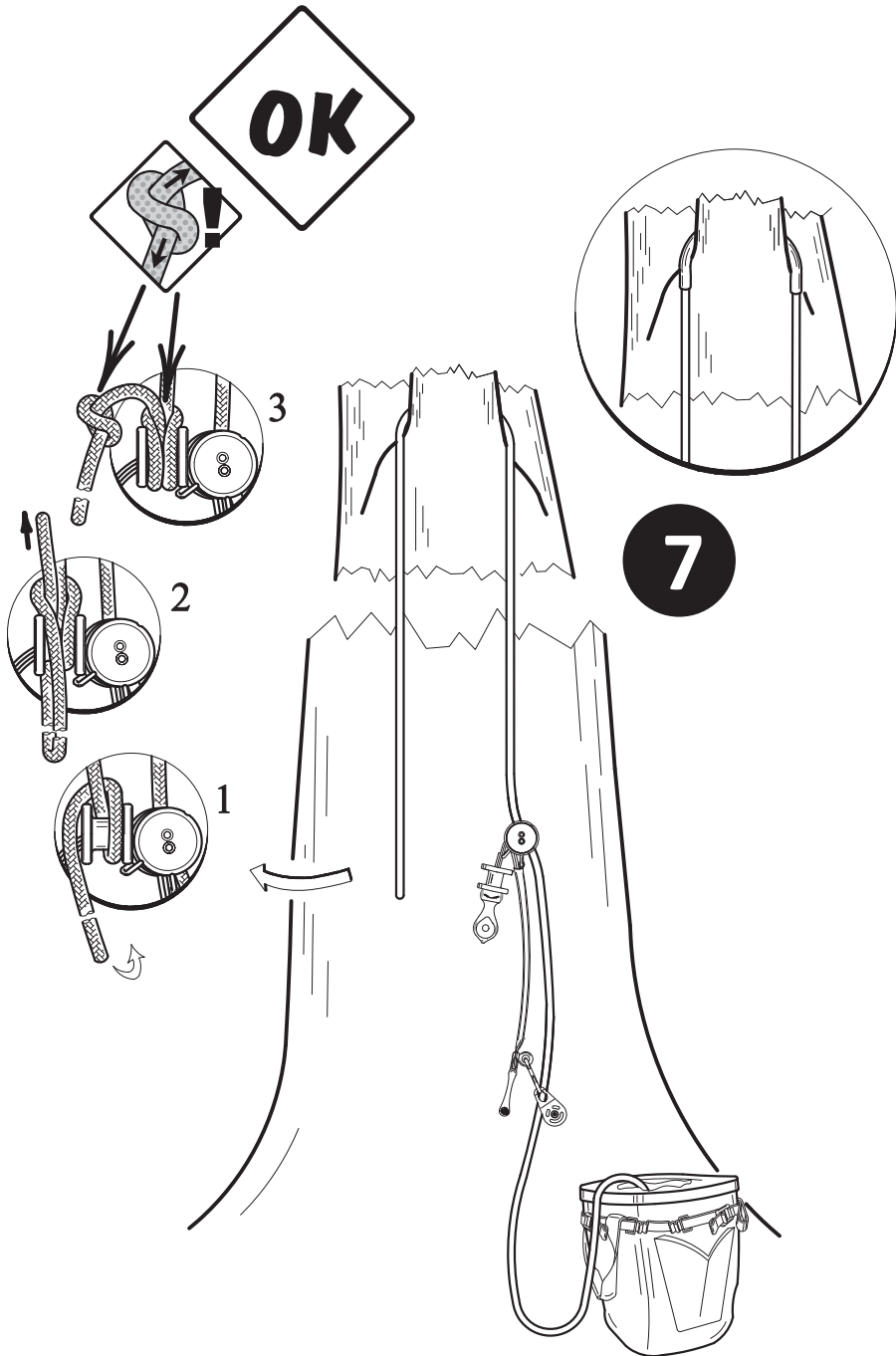

RopeGuide TwinLine:

8

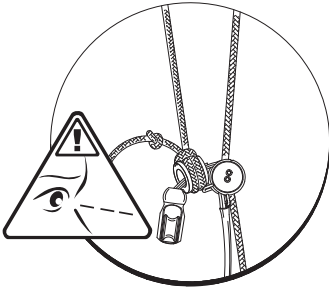

• SPIDERJACK 3

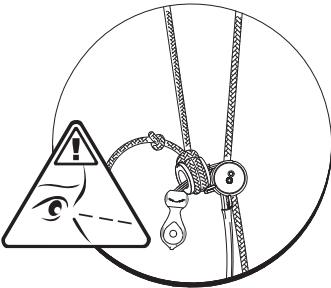

• SPIDERJACK
2.1 / 2.2

• LOCKJACK

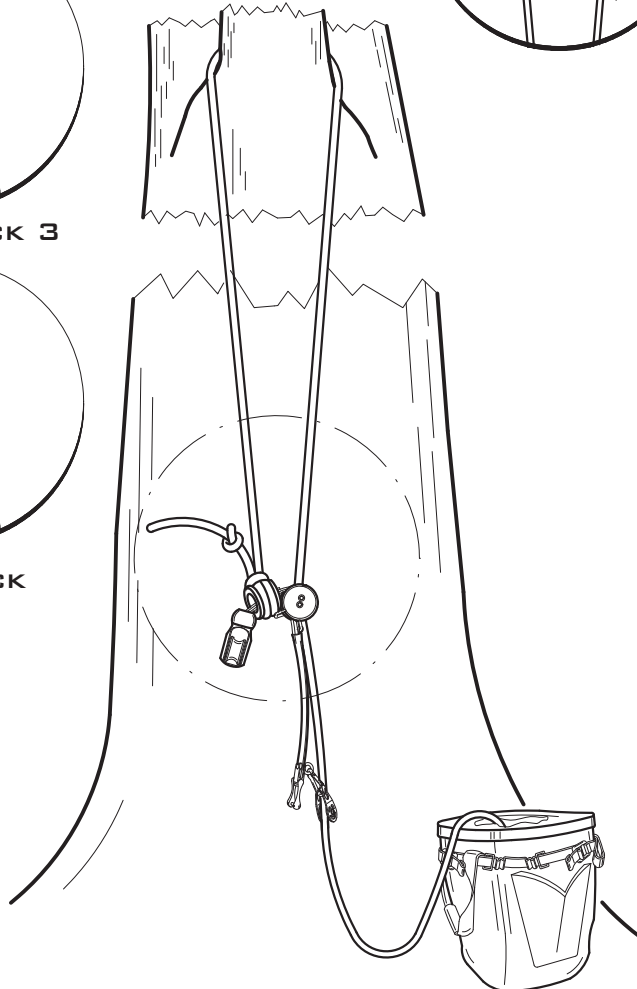
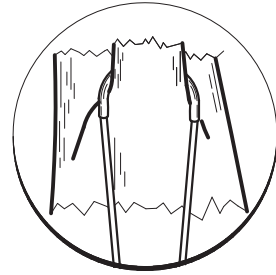

RopeGuide TwinLine:

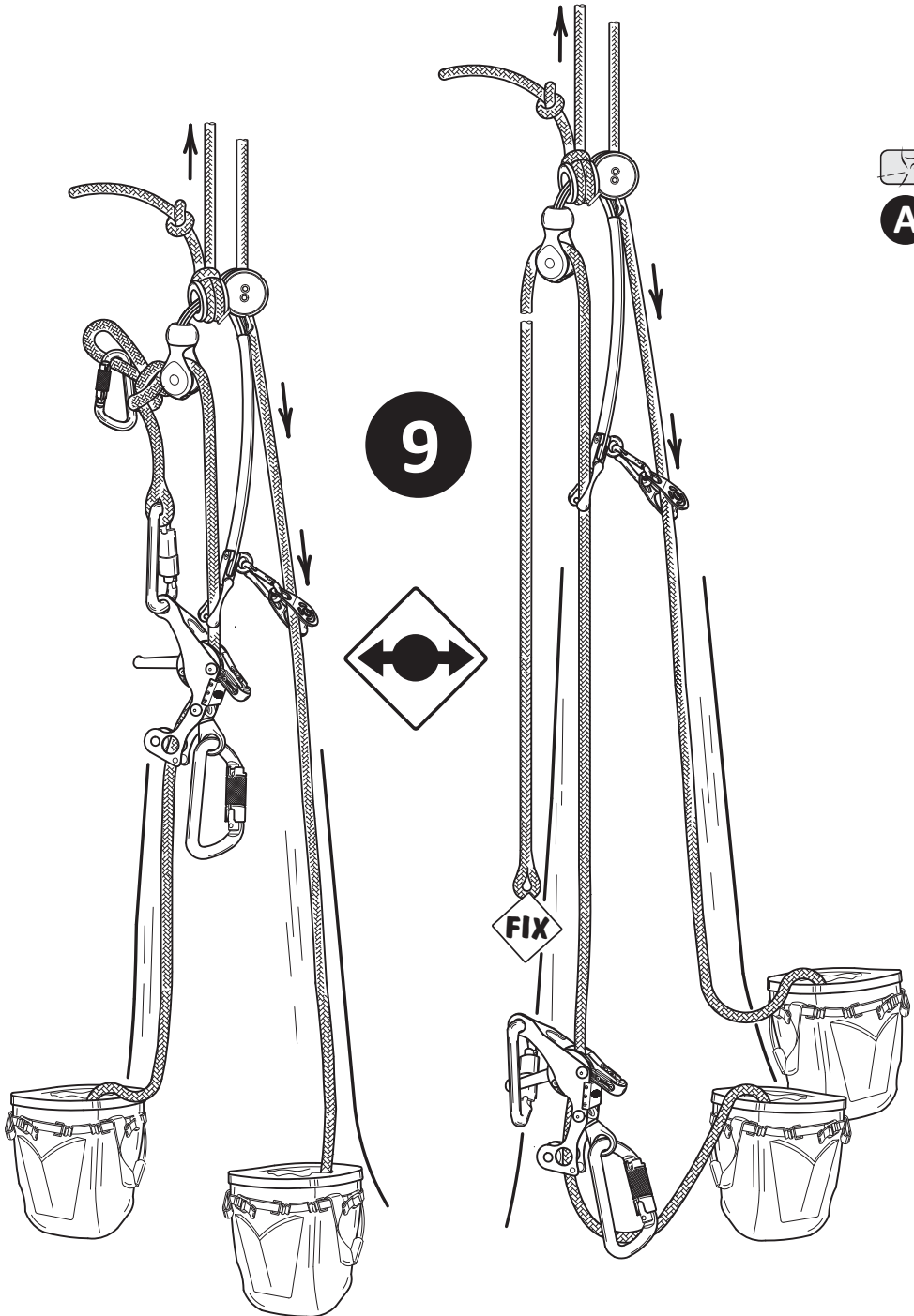

RopeGuide TwinLine:

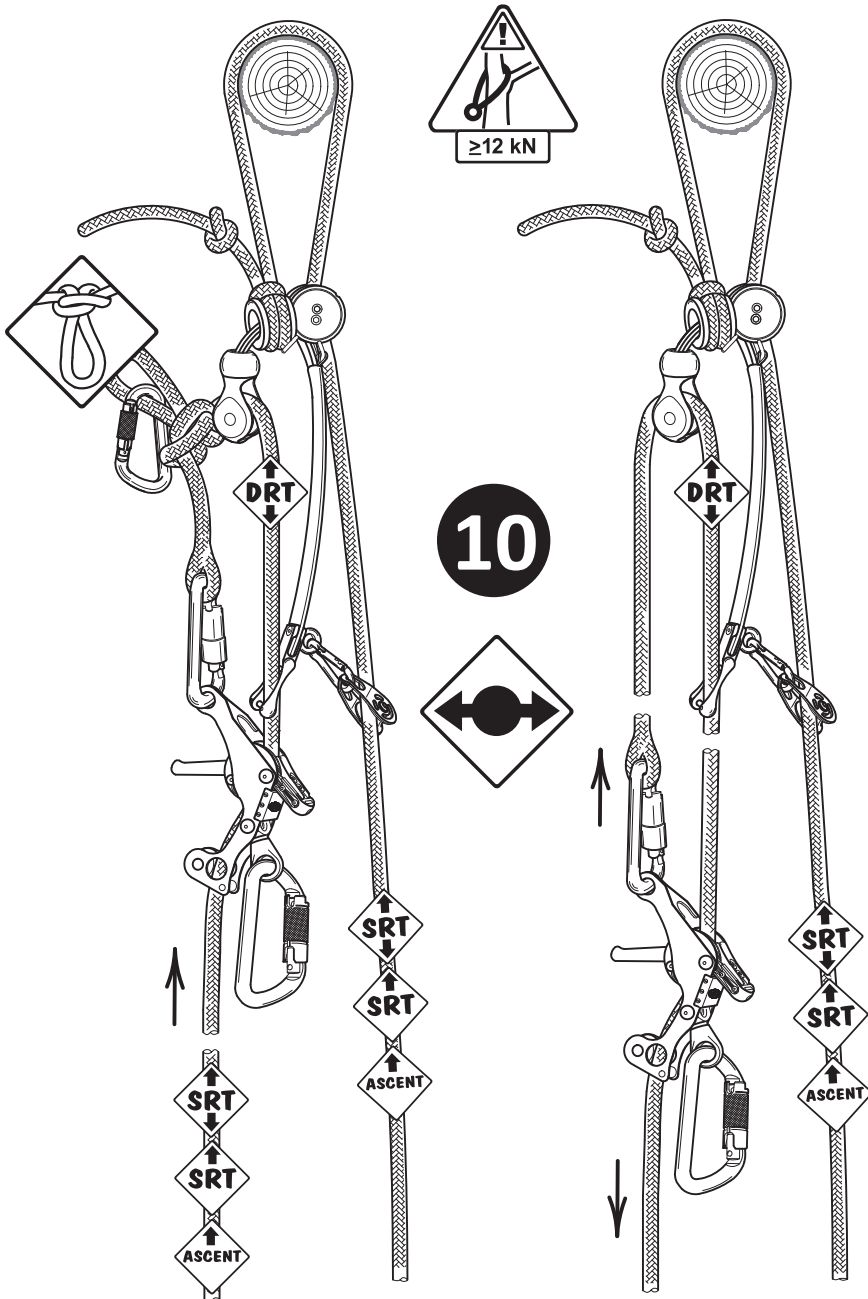

RopeGuide TwinLine:

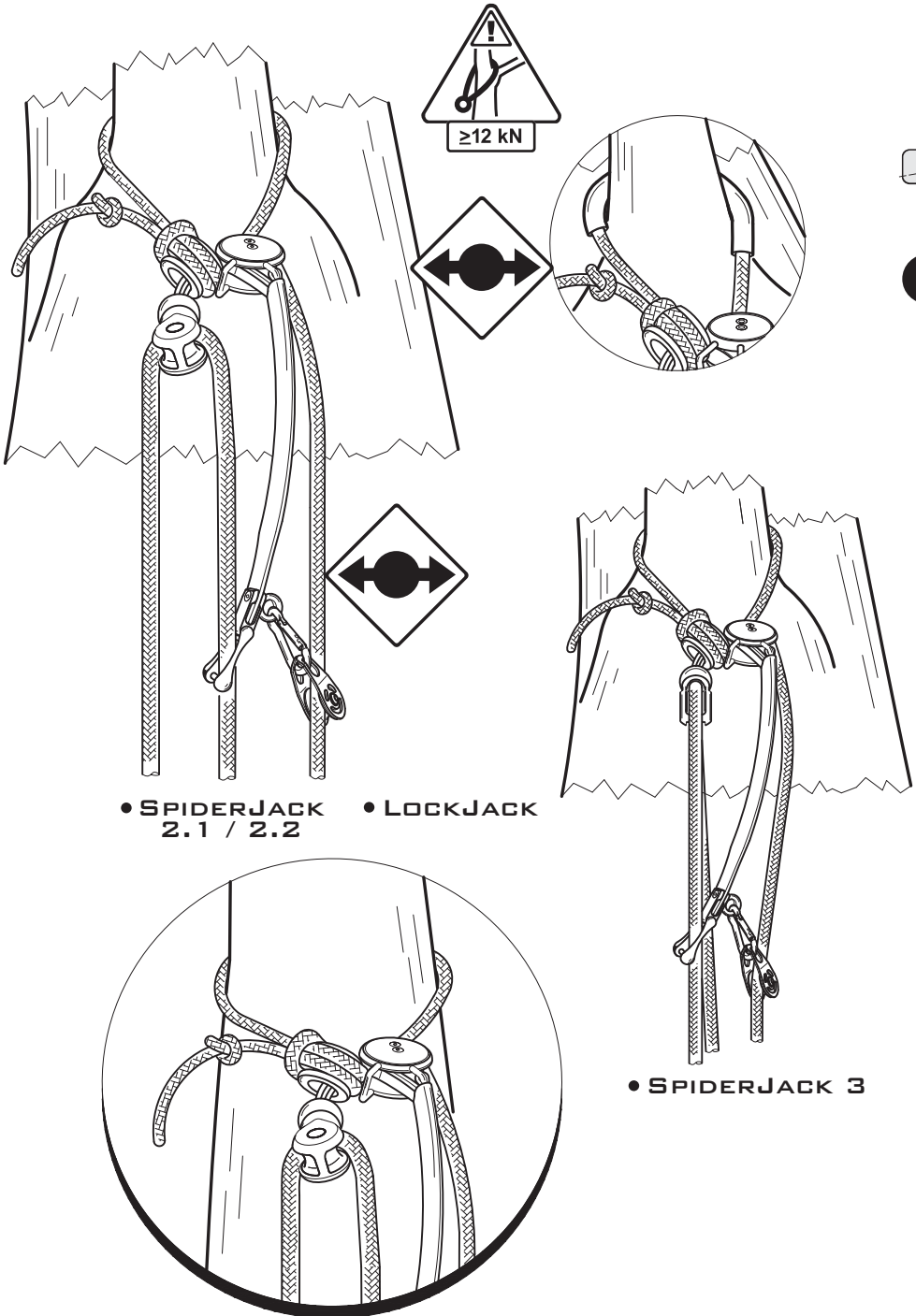

• SPIDERJACK 2.1 / 2.2 • LOCKJACK

• SPIDERJACK 3



For The **ART** Of Treeclimbing

RopeGuide TwinLine:

1

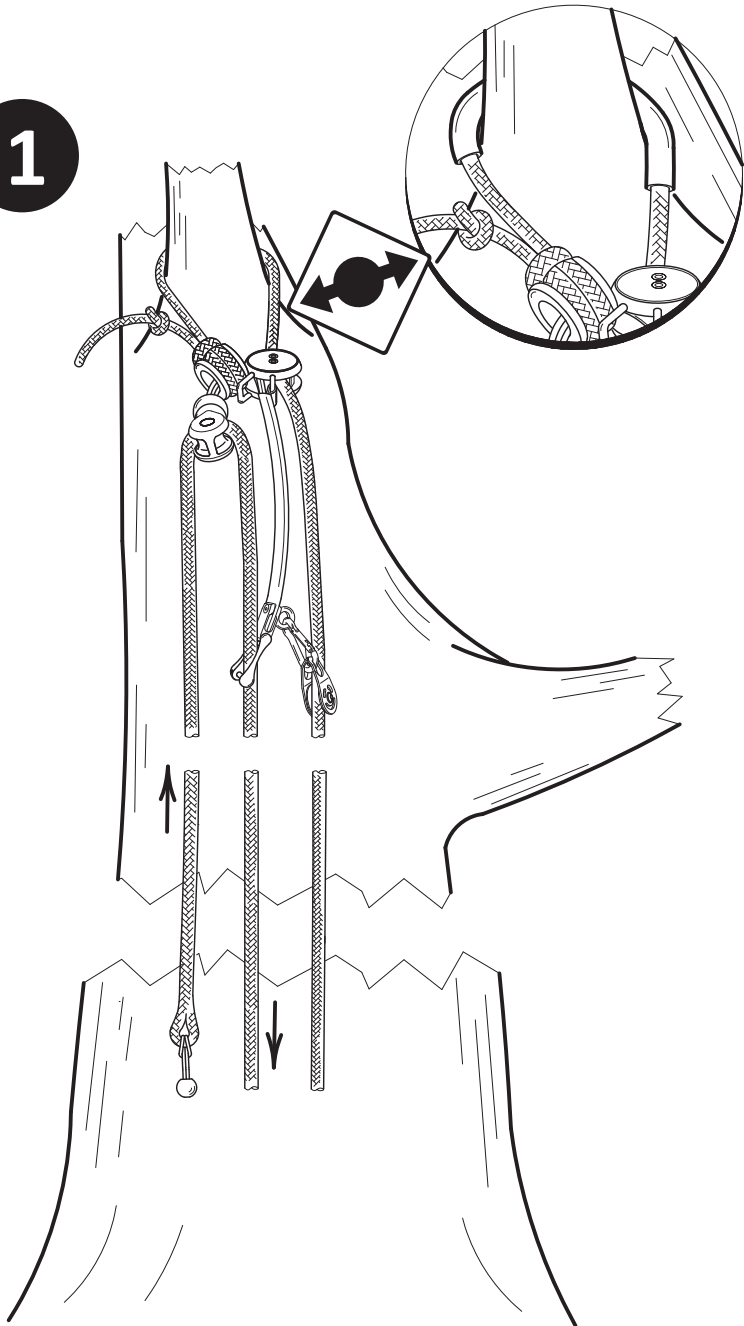

RopeGuide TwinLine:

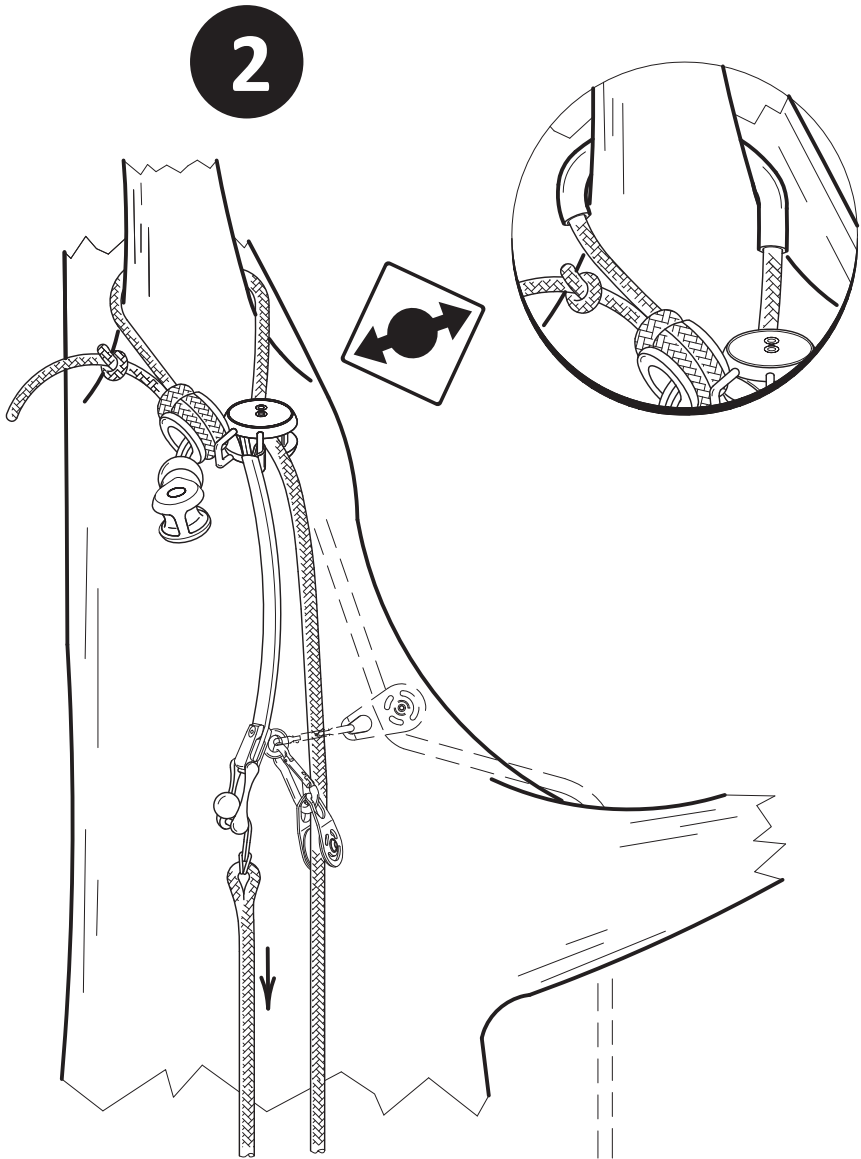

RopeGuide TwinLine:

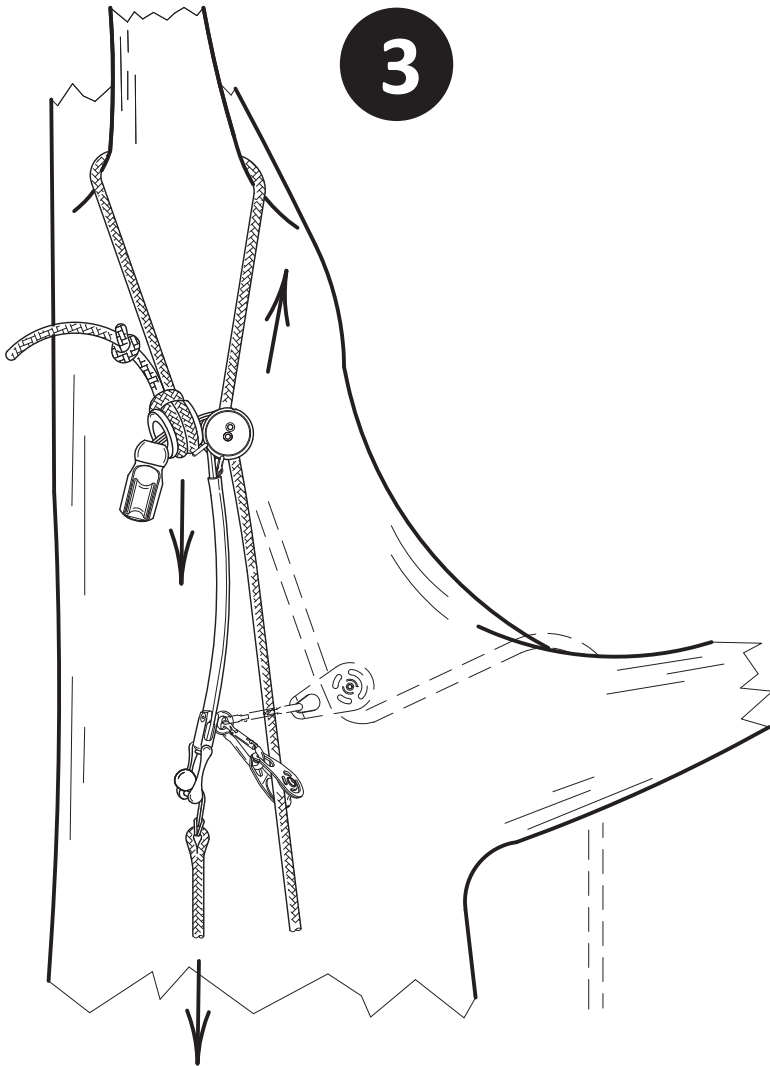

RopeGuide TwinLine:

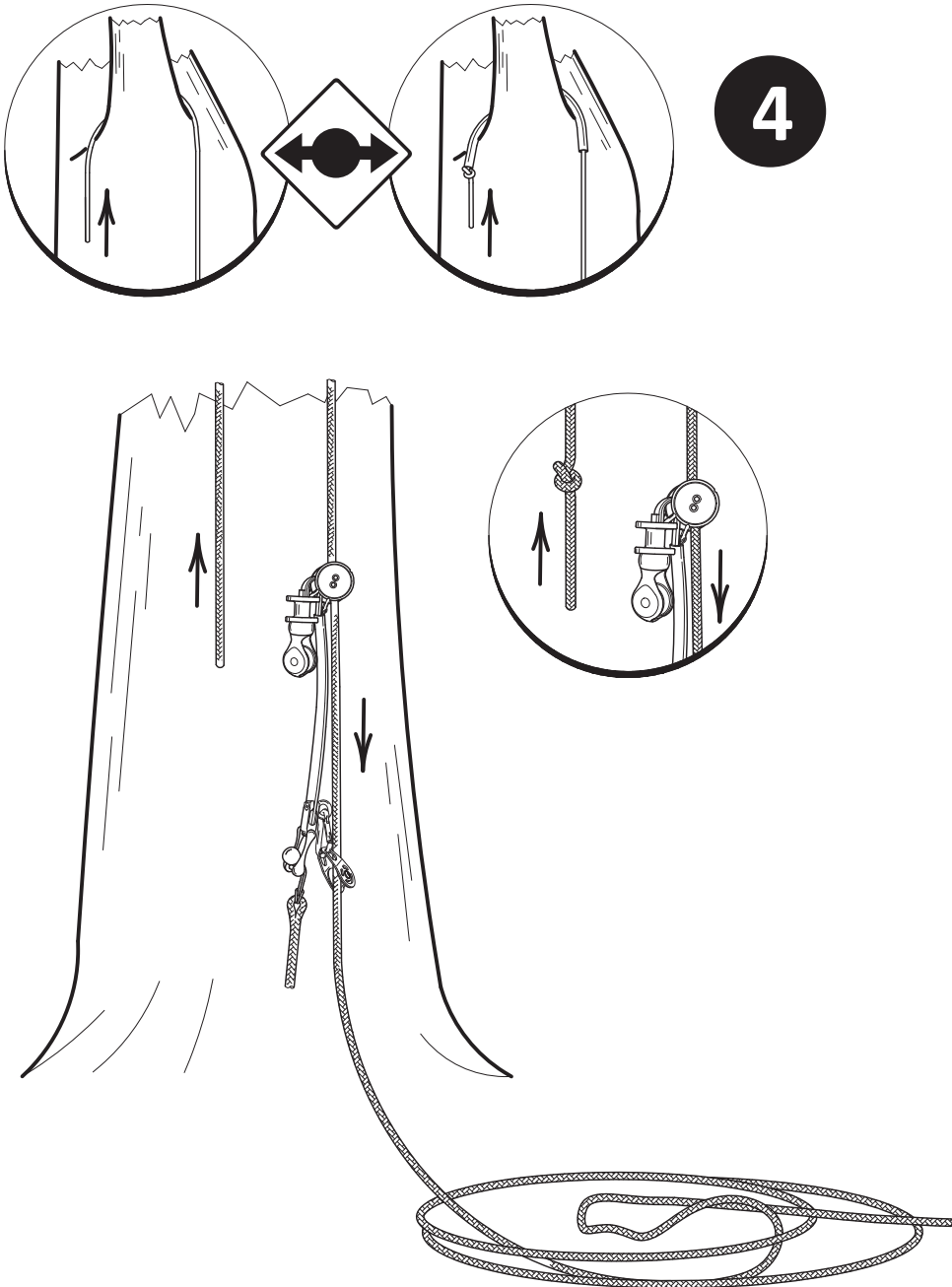

RopeGuide TwinLine:

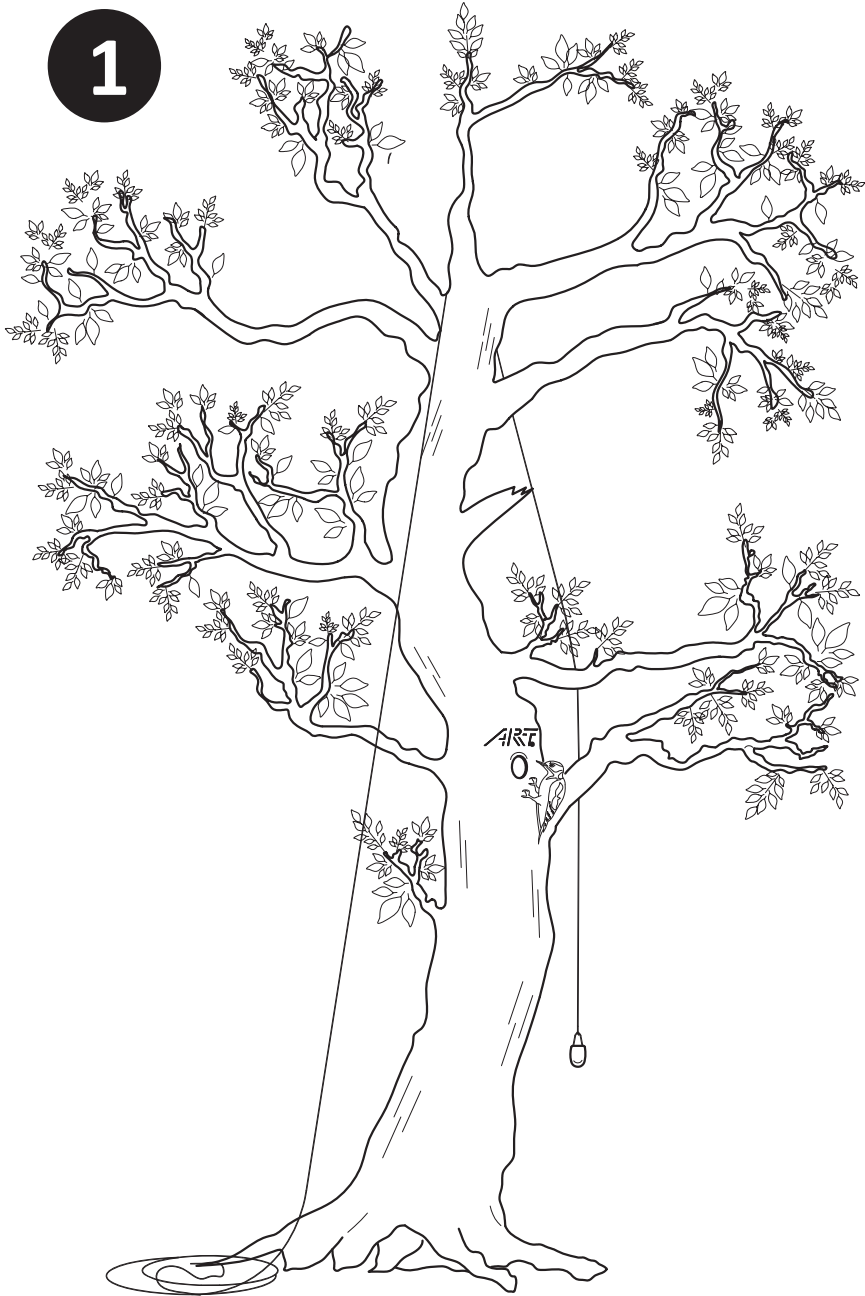

RopeGuide TwinLine:

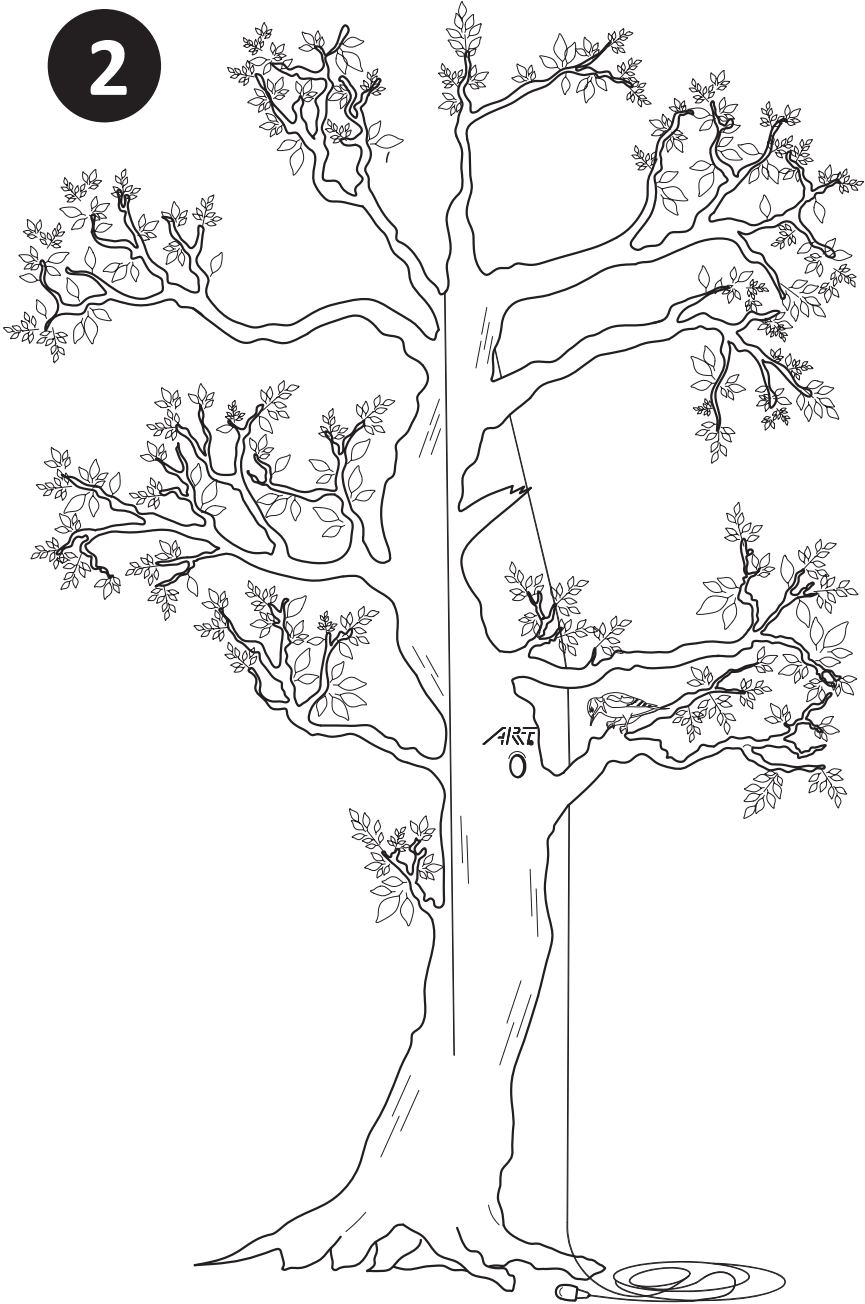

RopeGuide TwinLine:

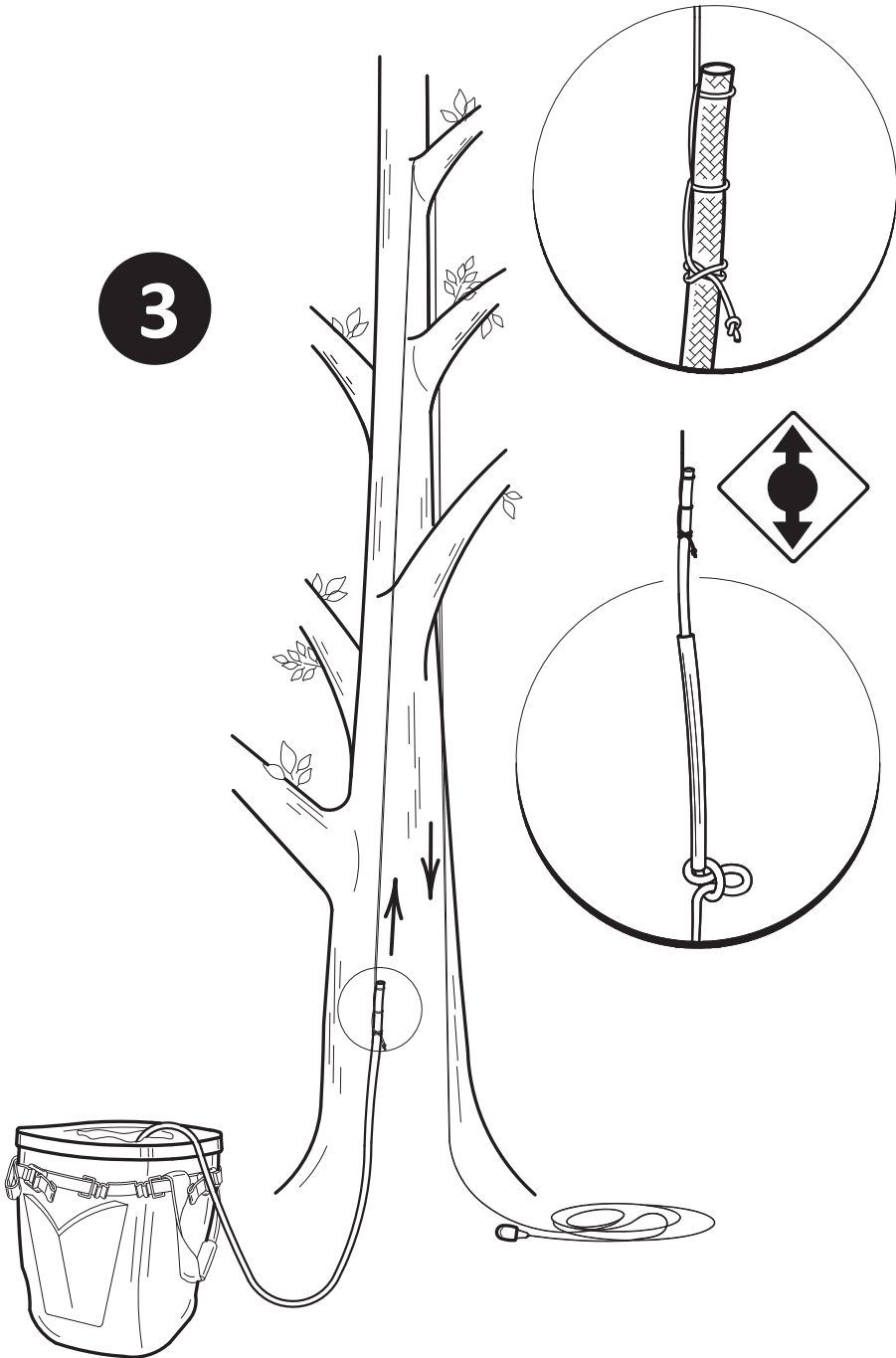

RopeGuide TwinLine:

4

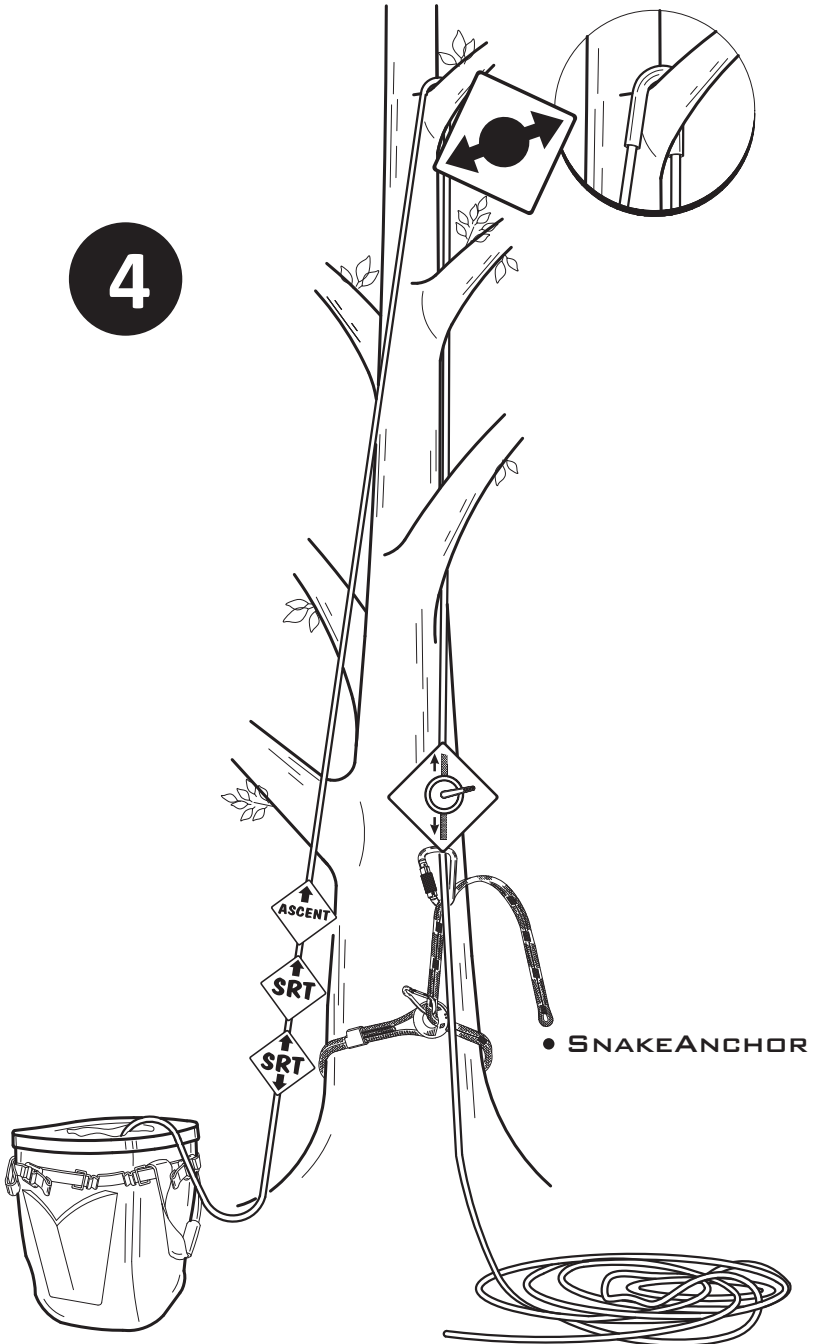

RopeGuide TwinLine:

5

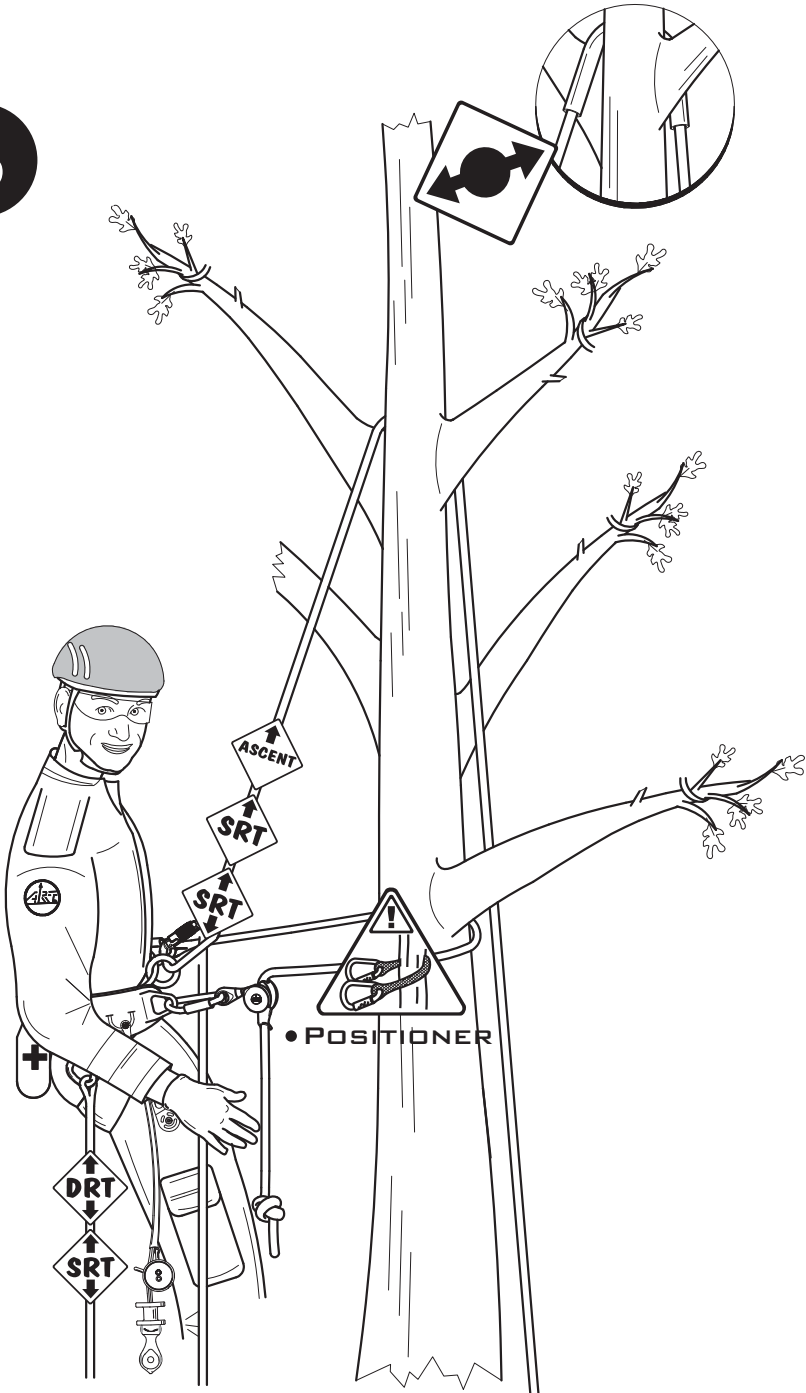

D

RopeGuide TwinLine:

6



RopeGuide TwinLine:

7

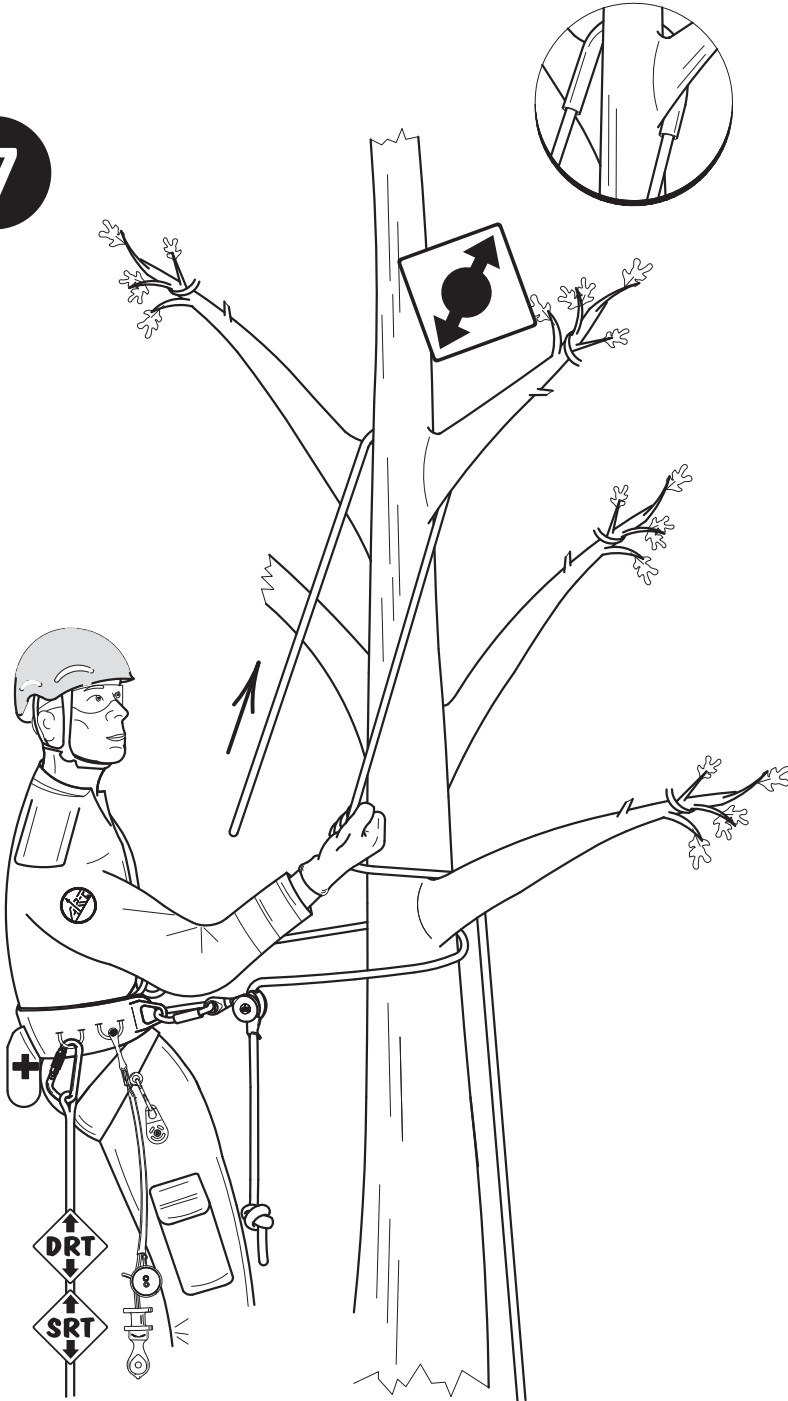

RopeGuide TwinLine:

8

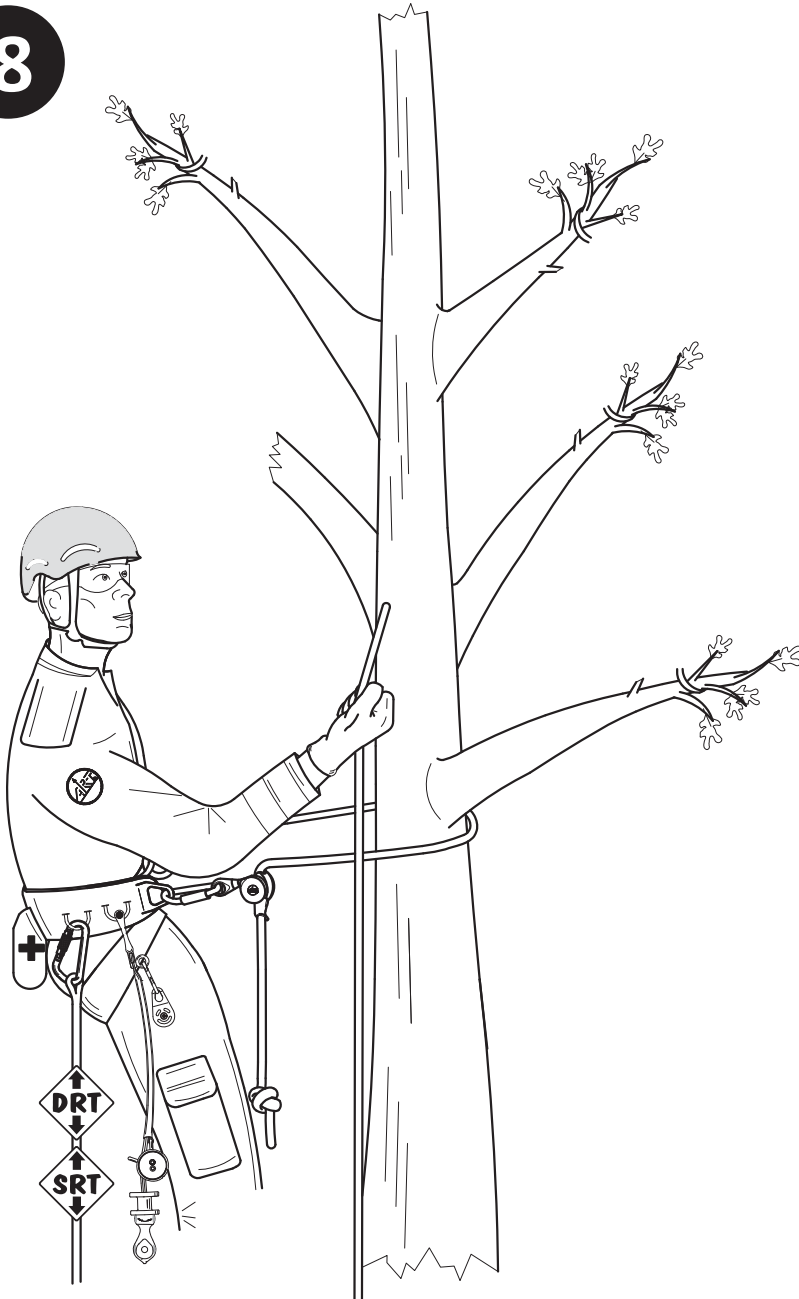

RopeGuide TwinLine:

9

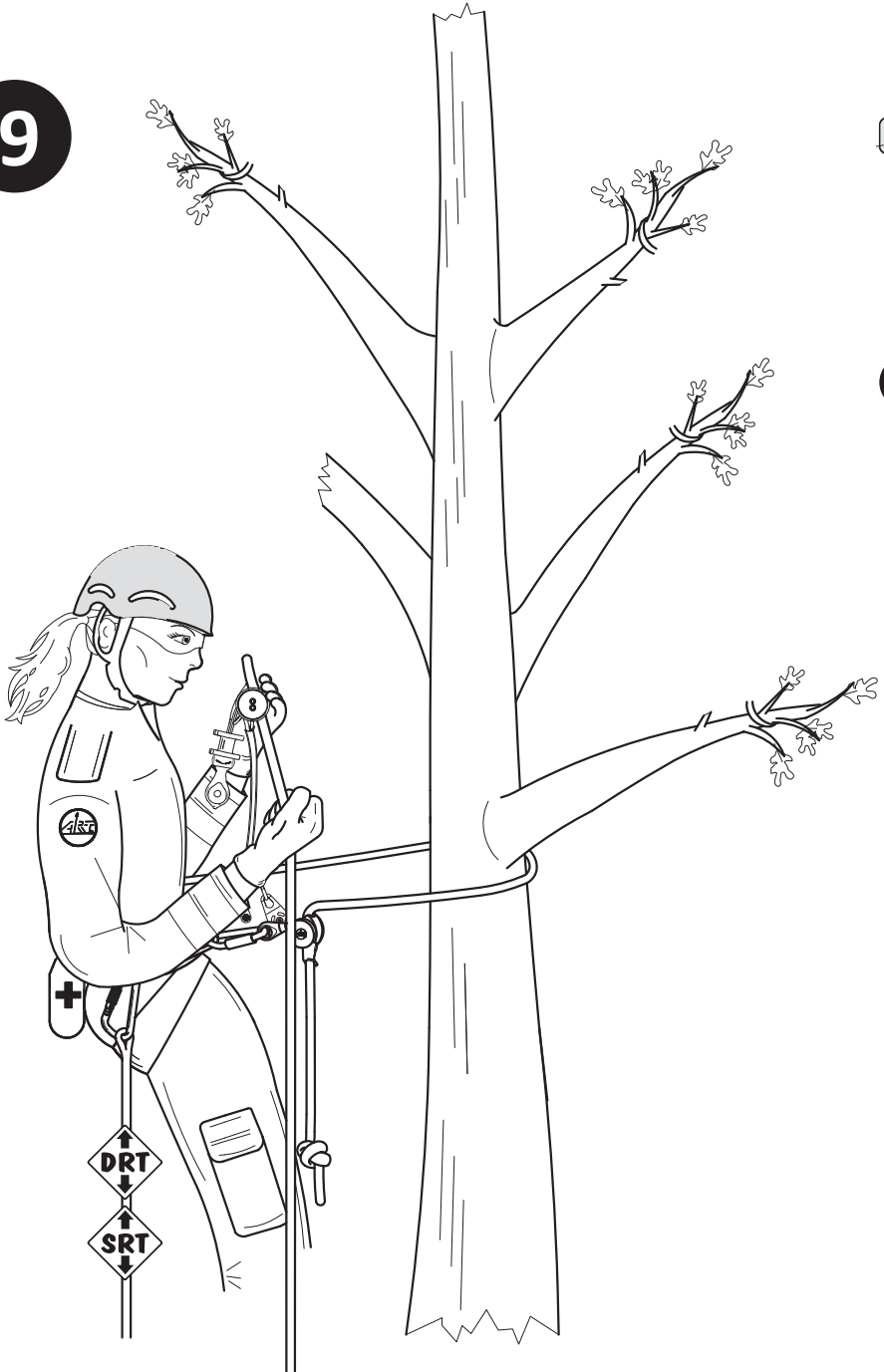

RopeGuide TwinLine:

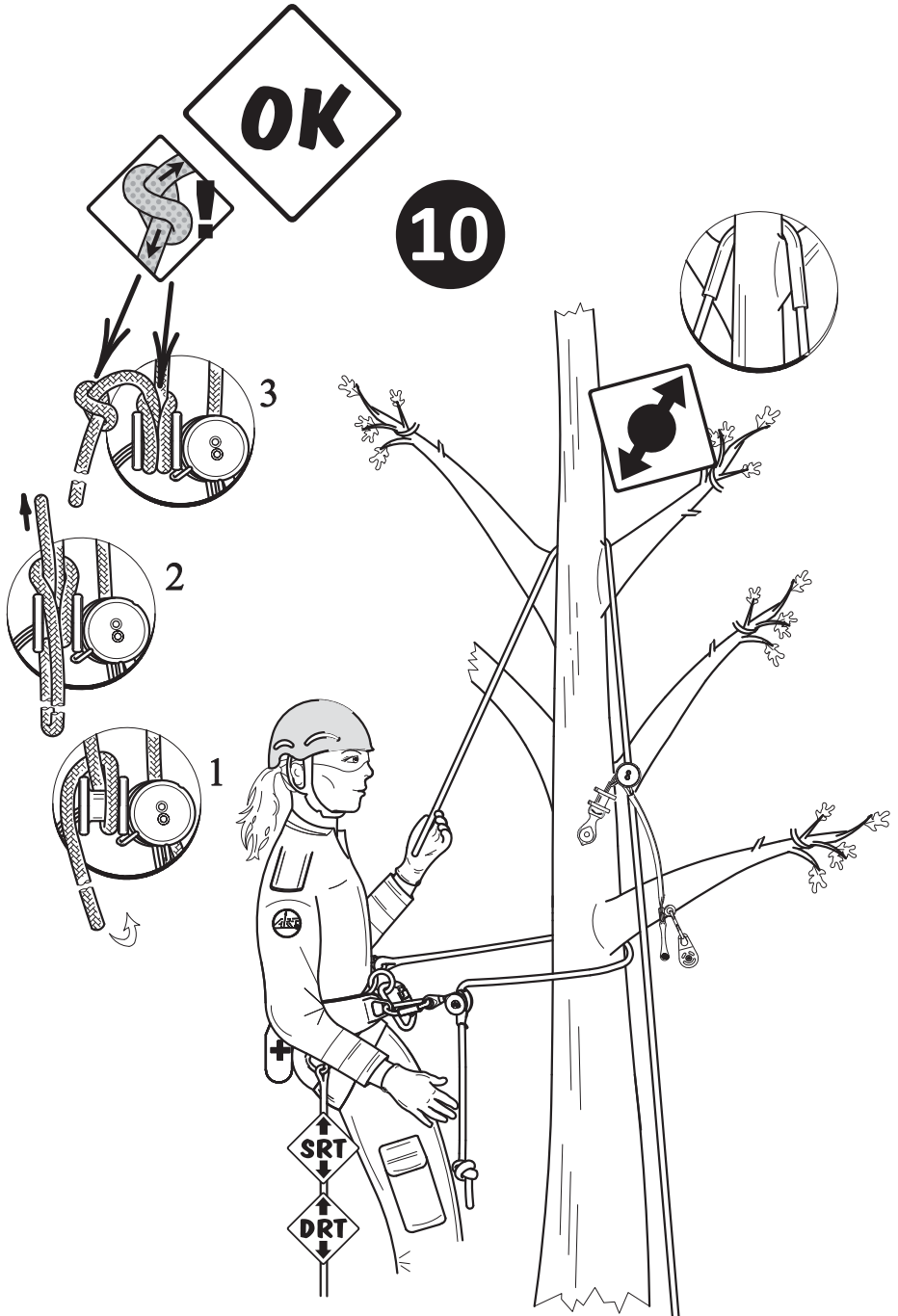

RopeGuide TwinLine:

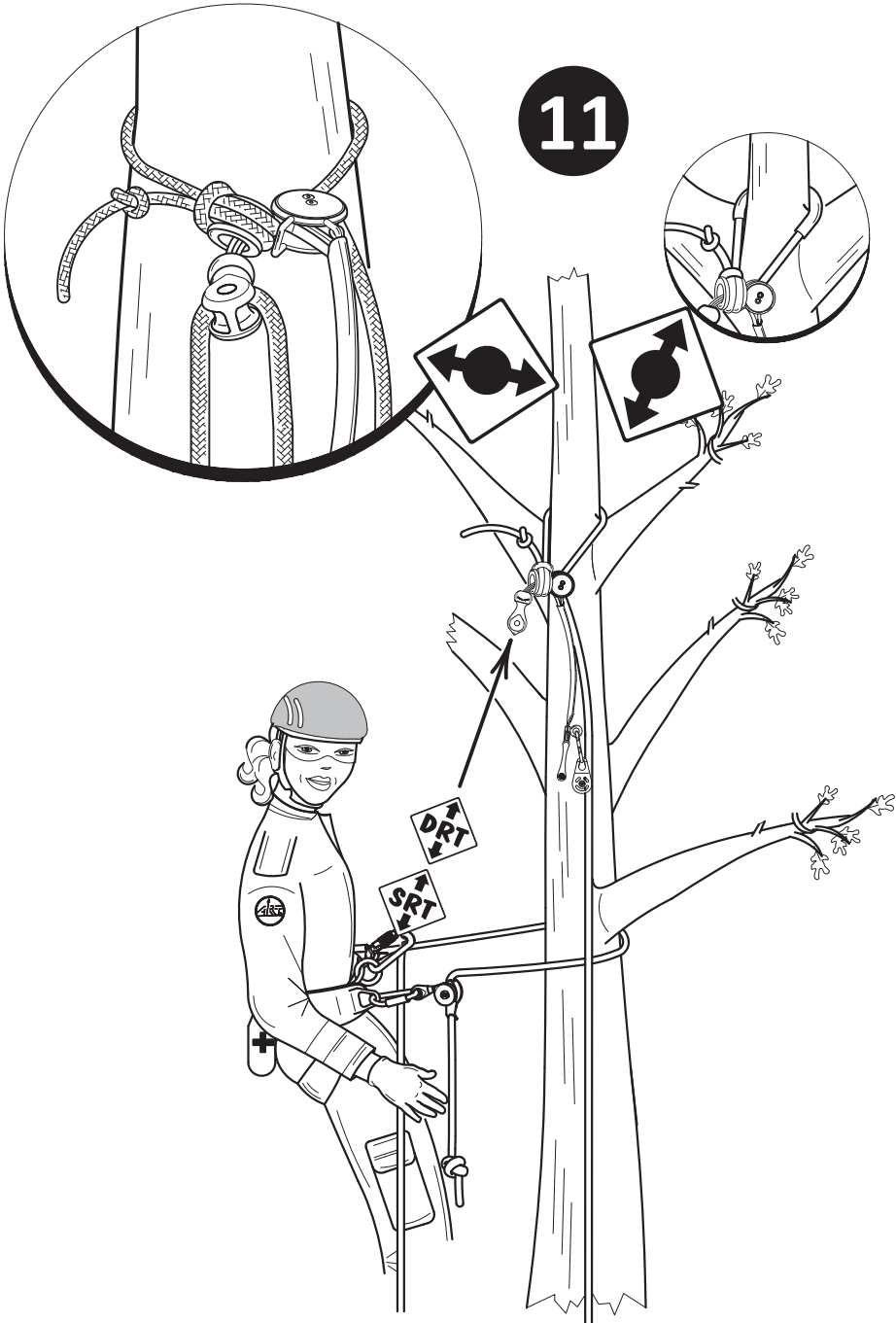



For The **ART** Of Treeclimbing

RopeGuide TwinLine:

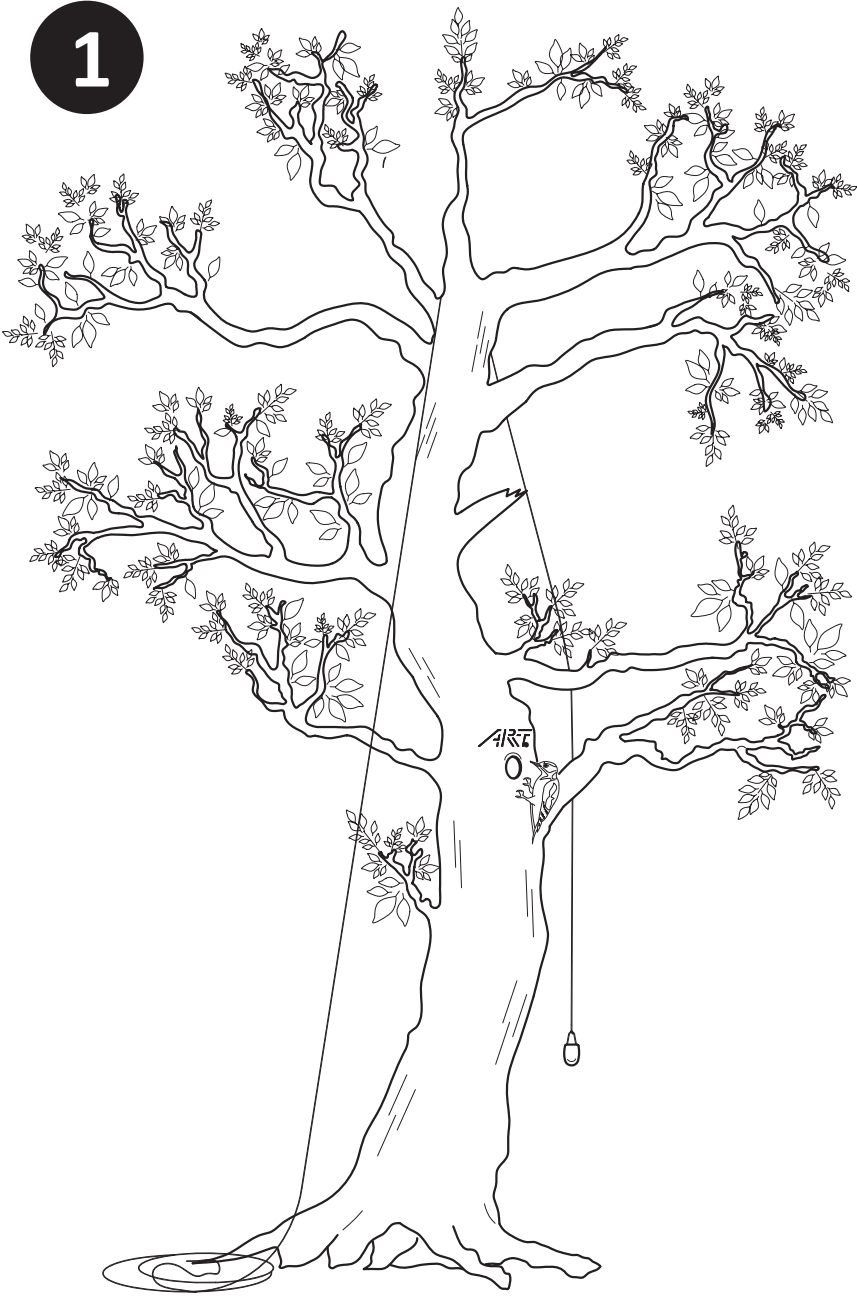

RopeGuide TwinLine:

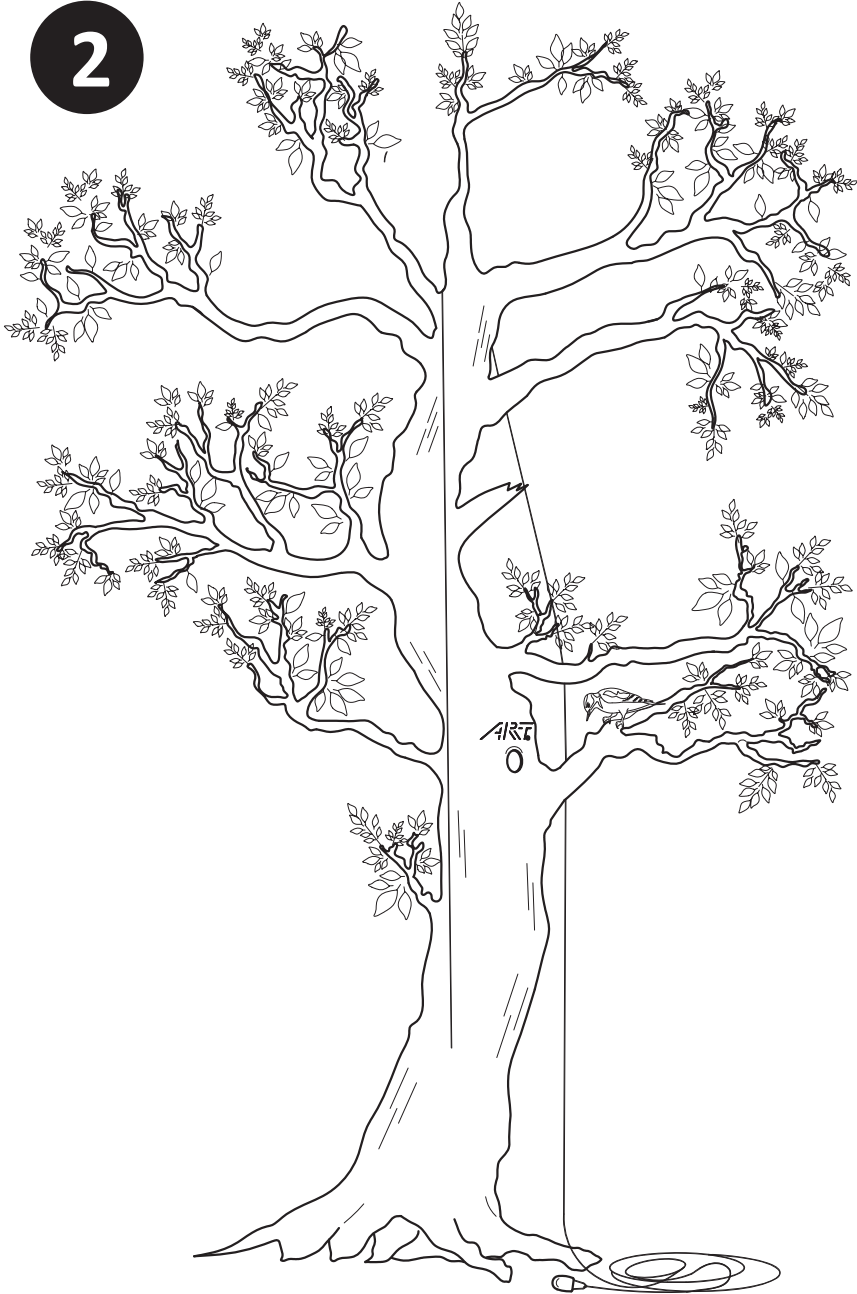

RopeGuide TwinLine:

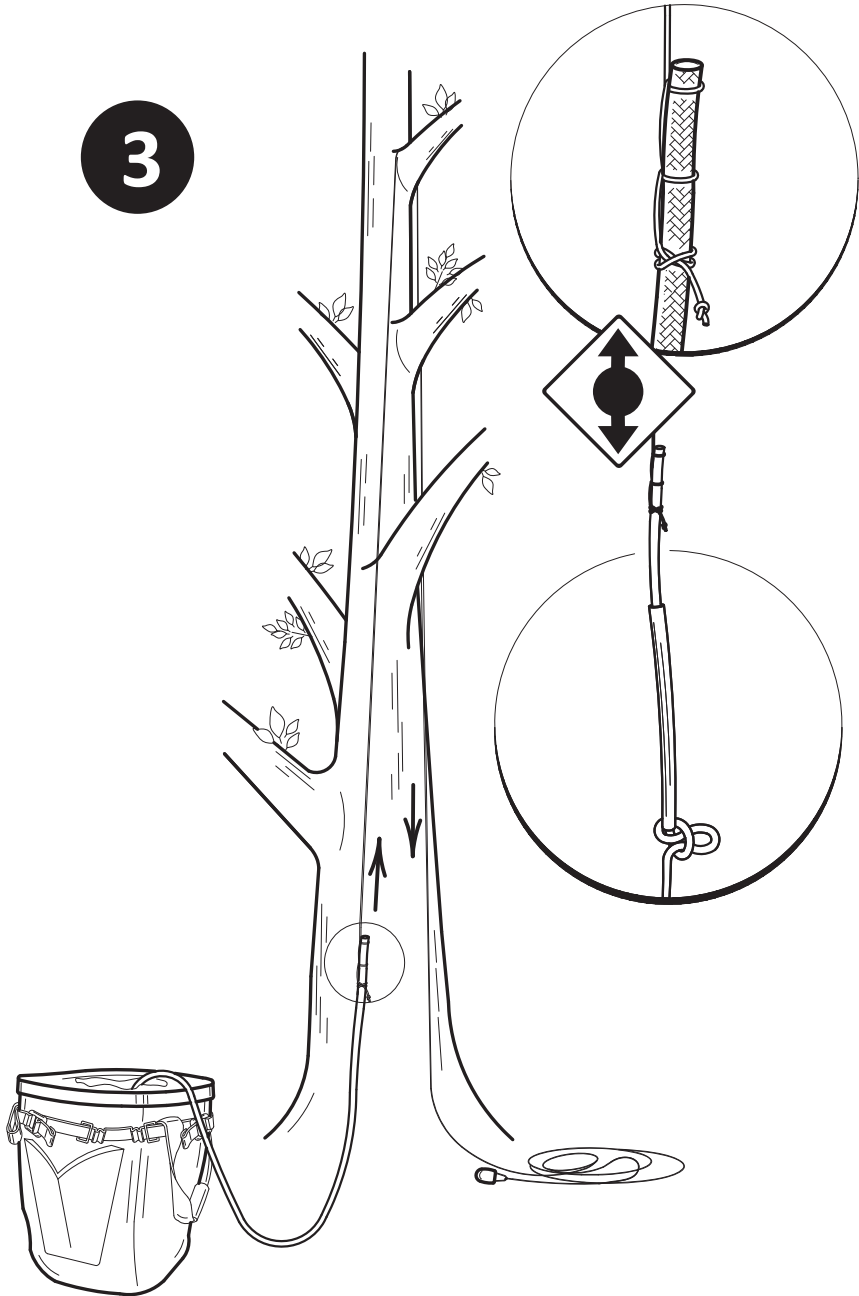

RopeGuide TwinLine:

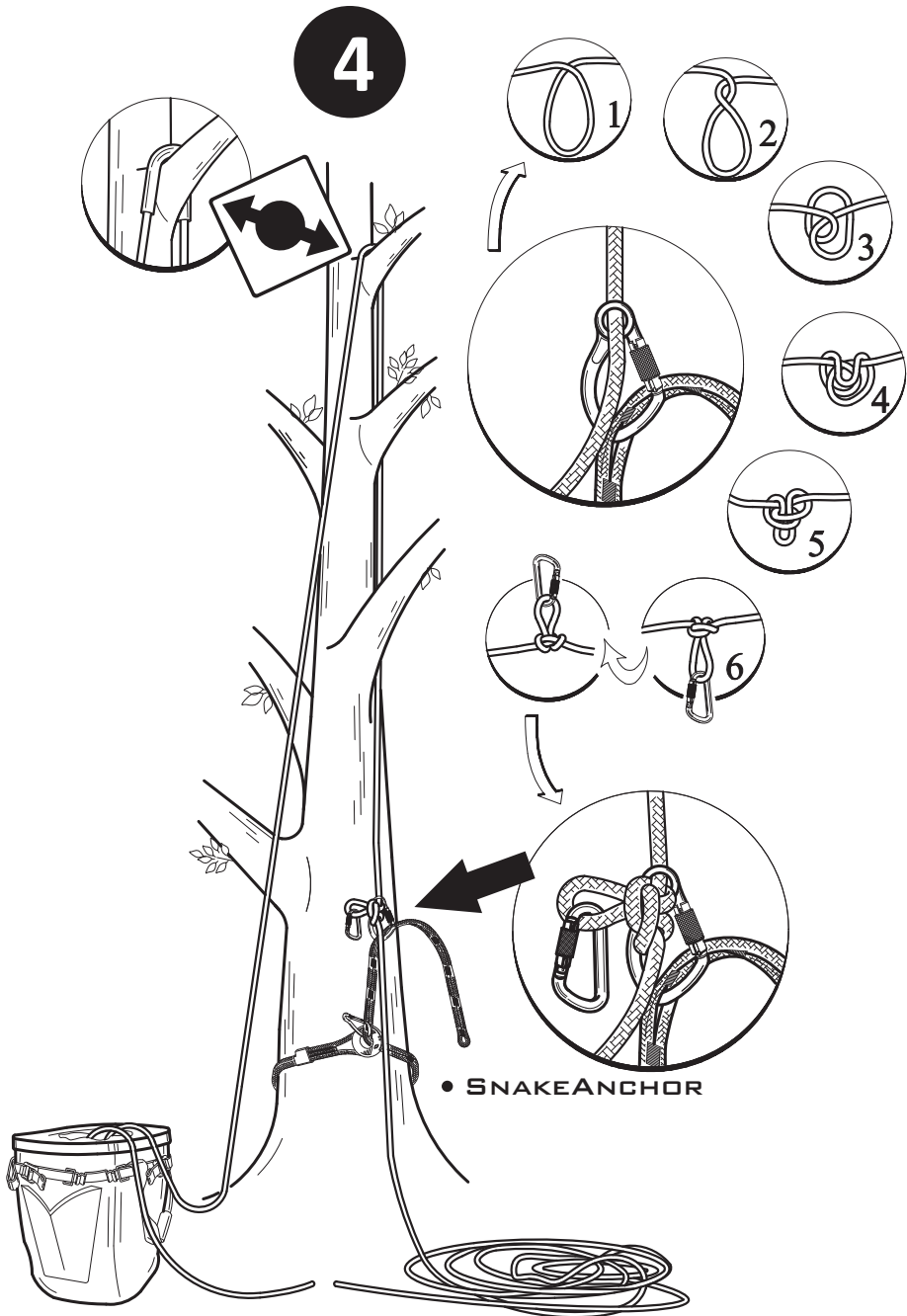

RopeGuide TwinLine:



5

E

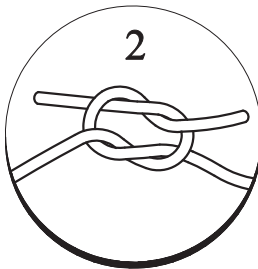
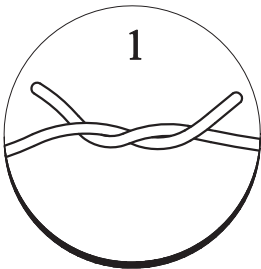
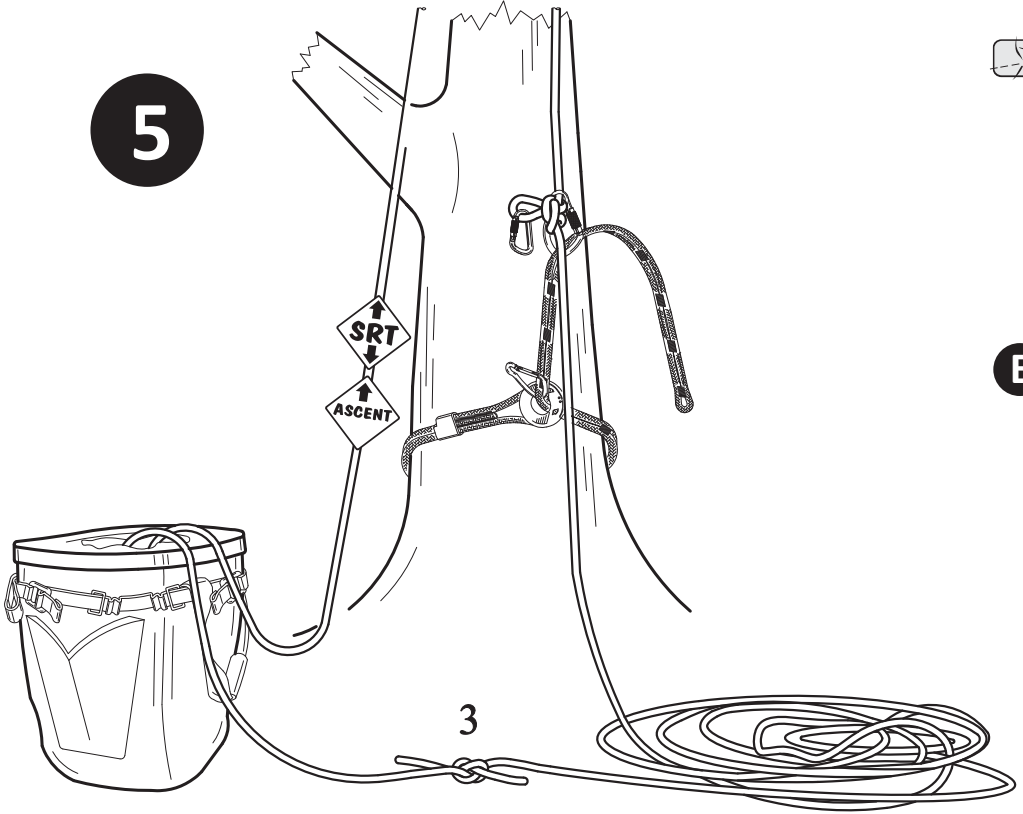

RopeGuide TwinLine:

6

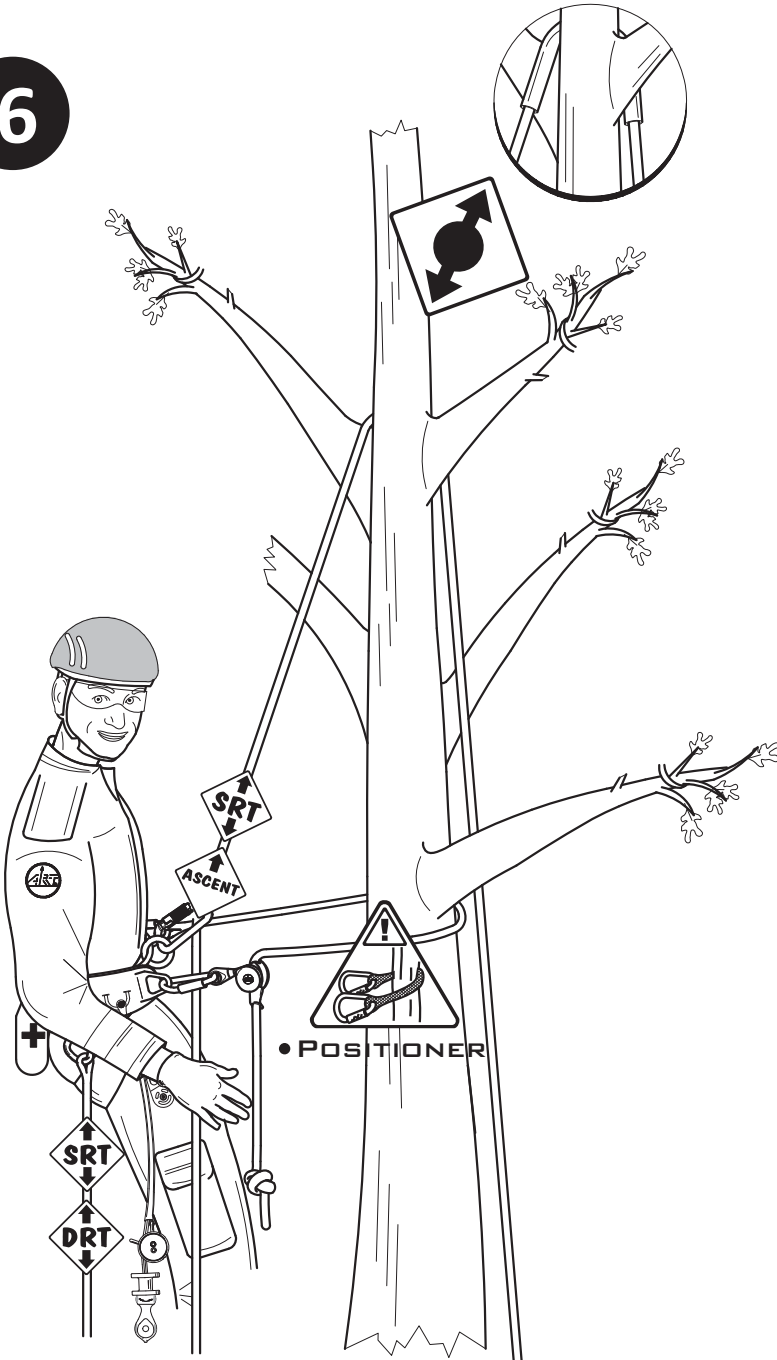

RopeGuide TwinLine:

7

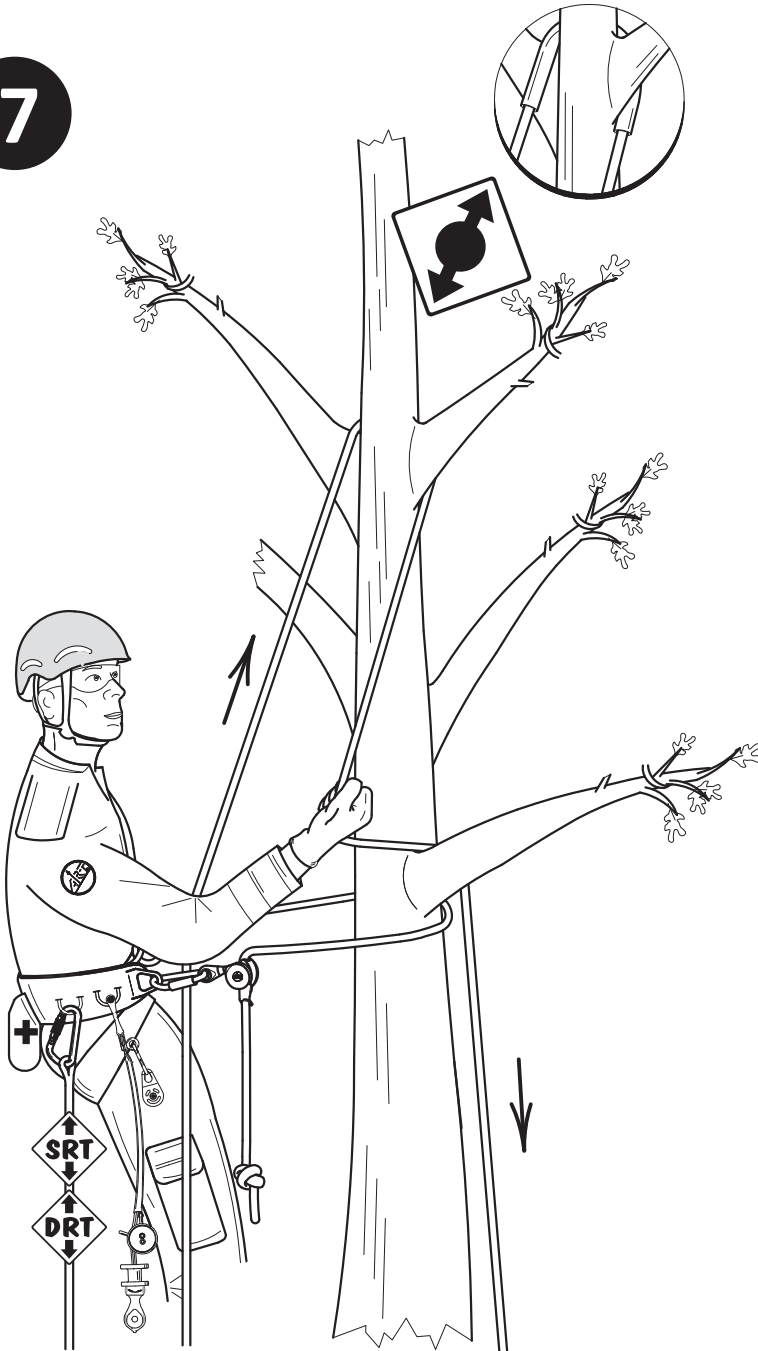

E

RopeGuide TwinLine:

8

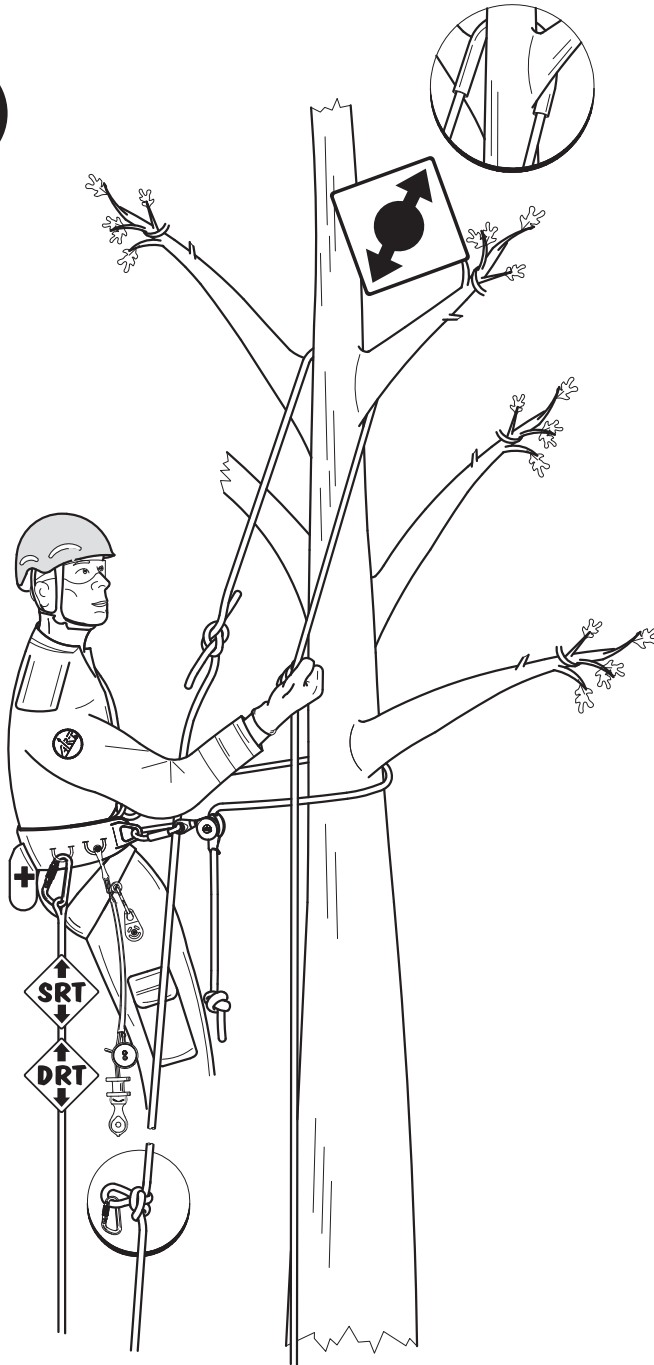

RopeGuide TwinLine:

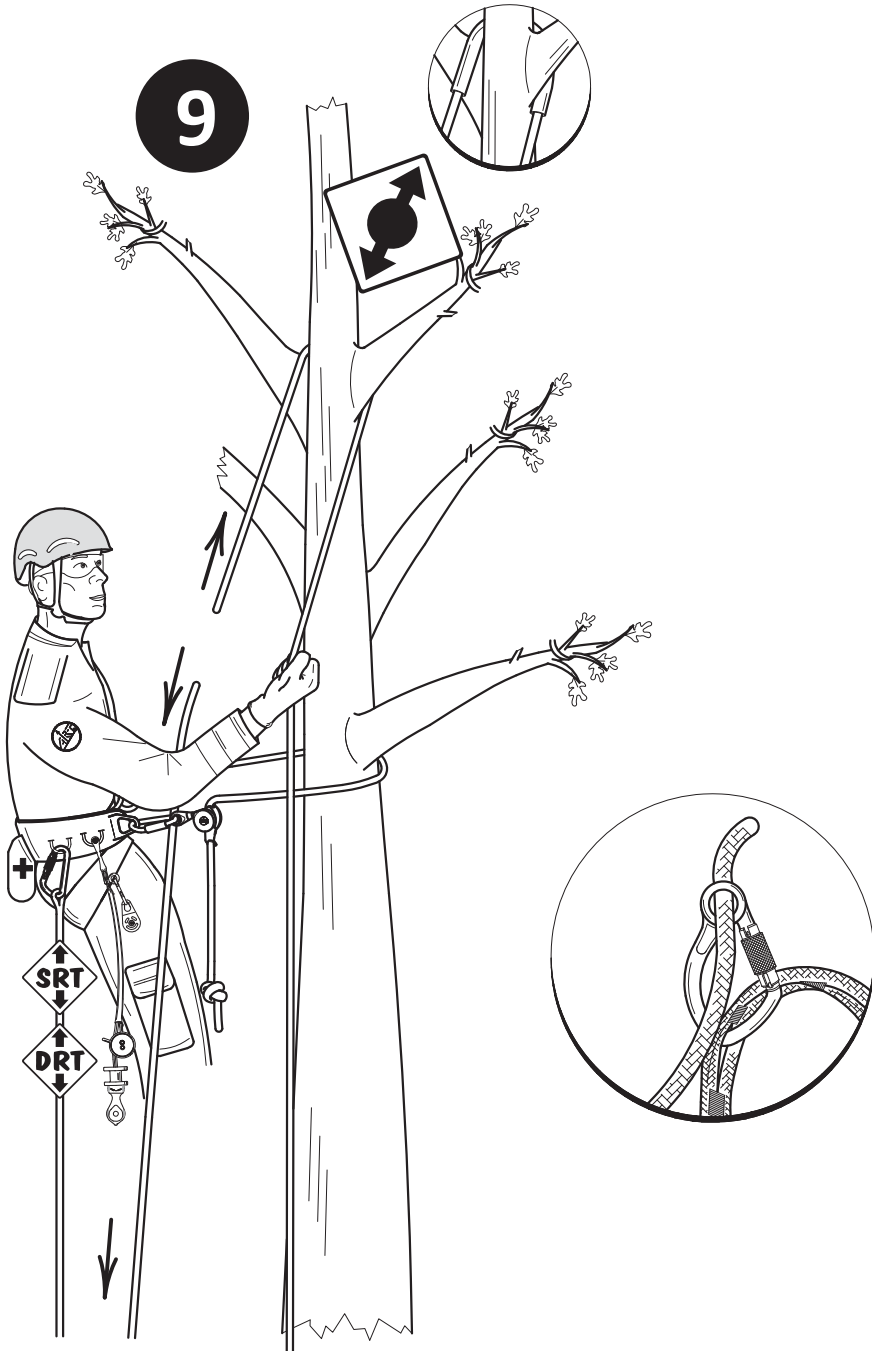

RopeGuide TwinLine:

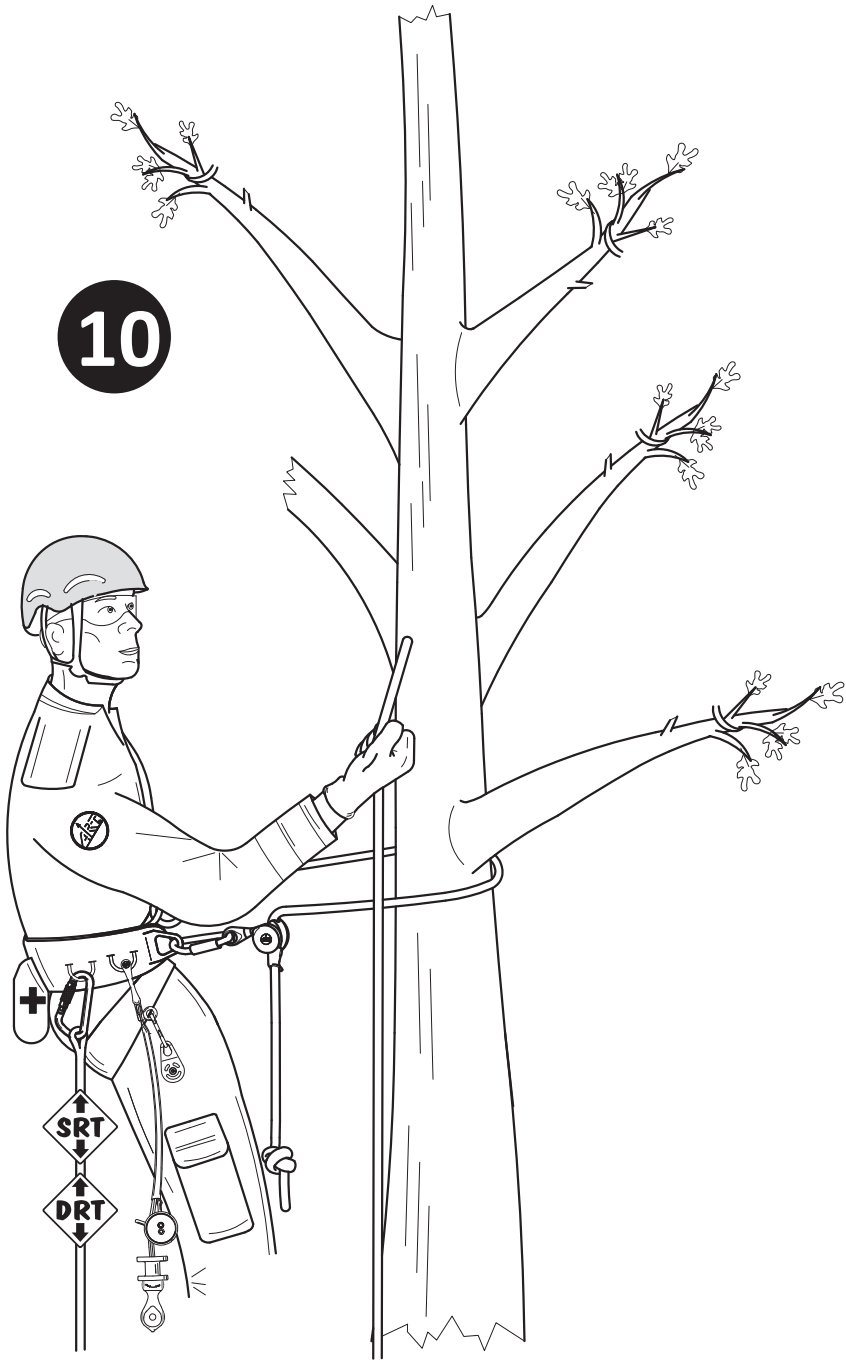

RopeGuide TwinLine:

11



E

RopeGuide TwinLine:

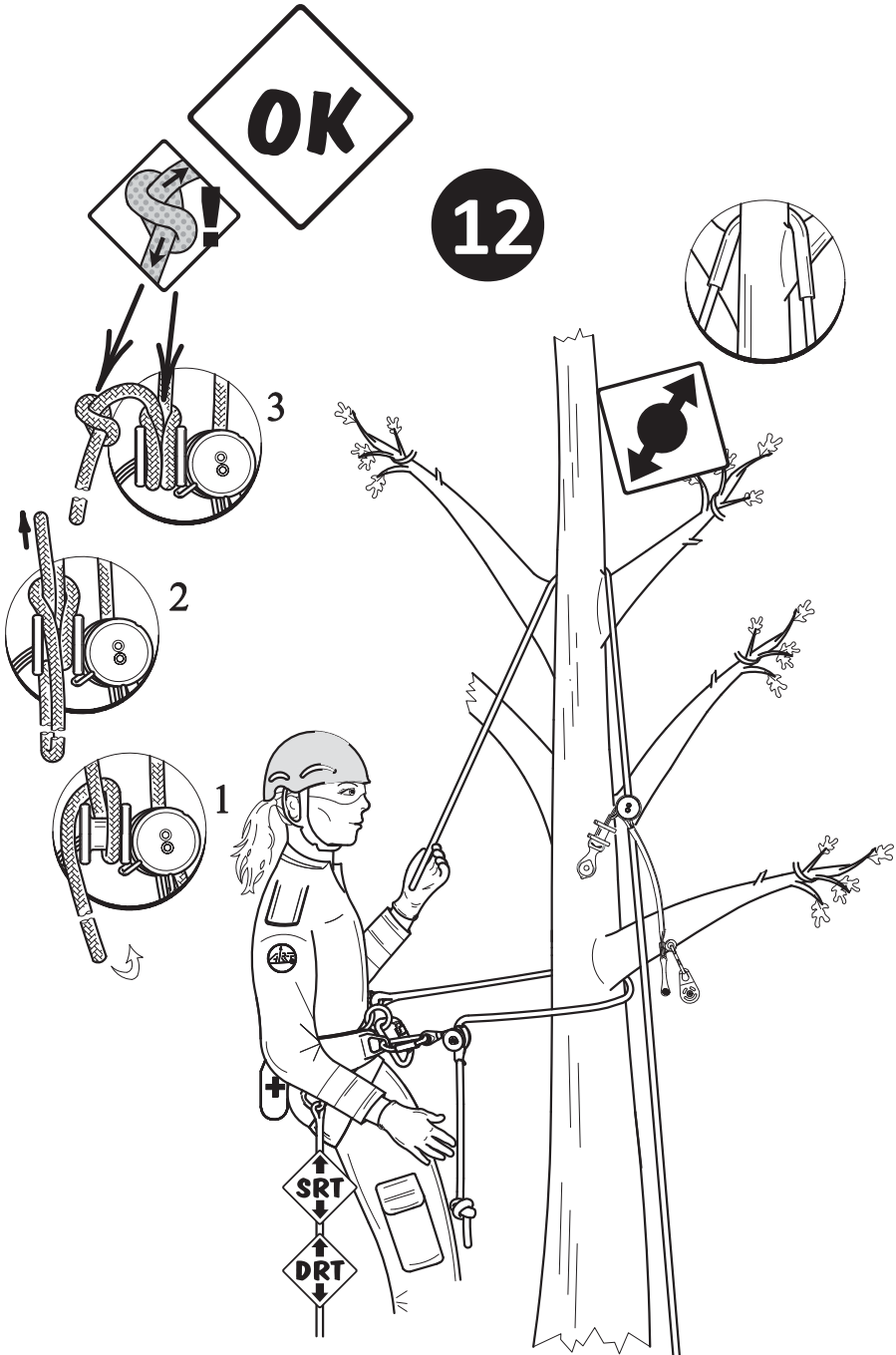

RopeGuide TwinLine:

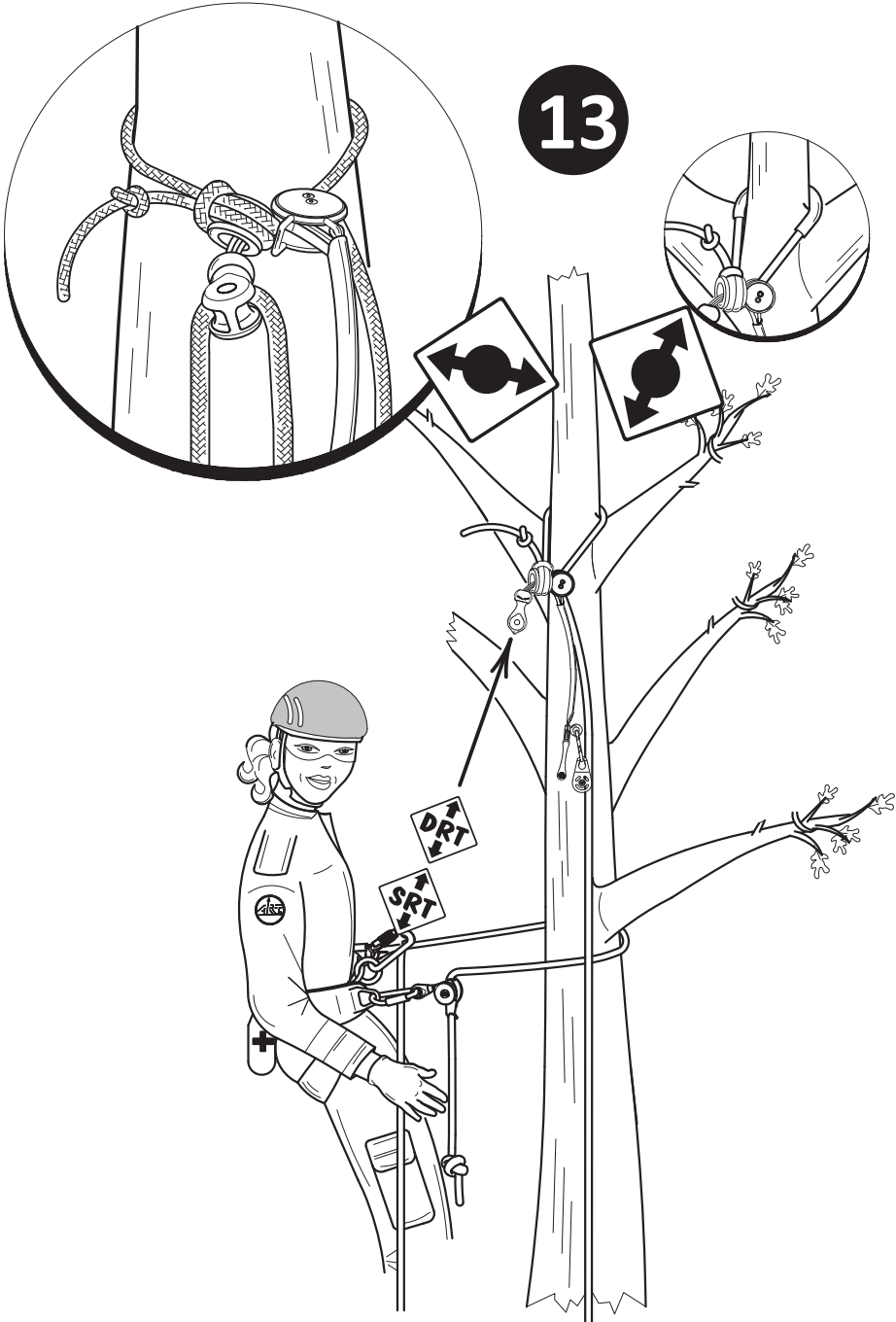



For The **ART** Of Treeclimbing

RopeGuide TwinLine:

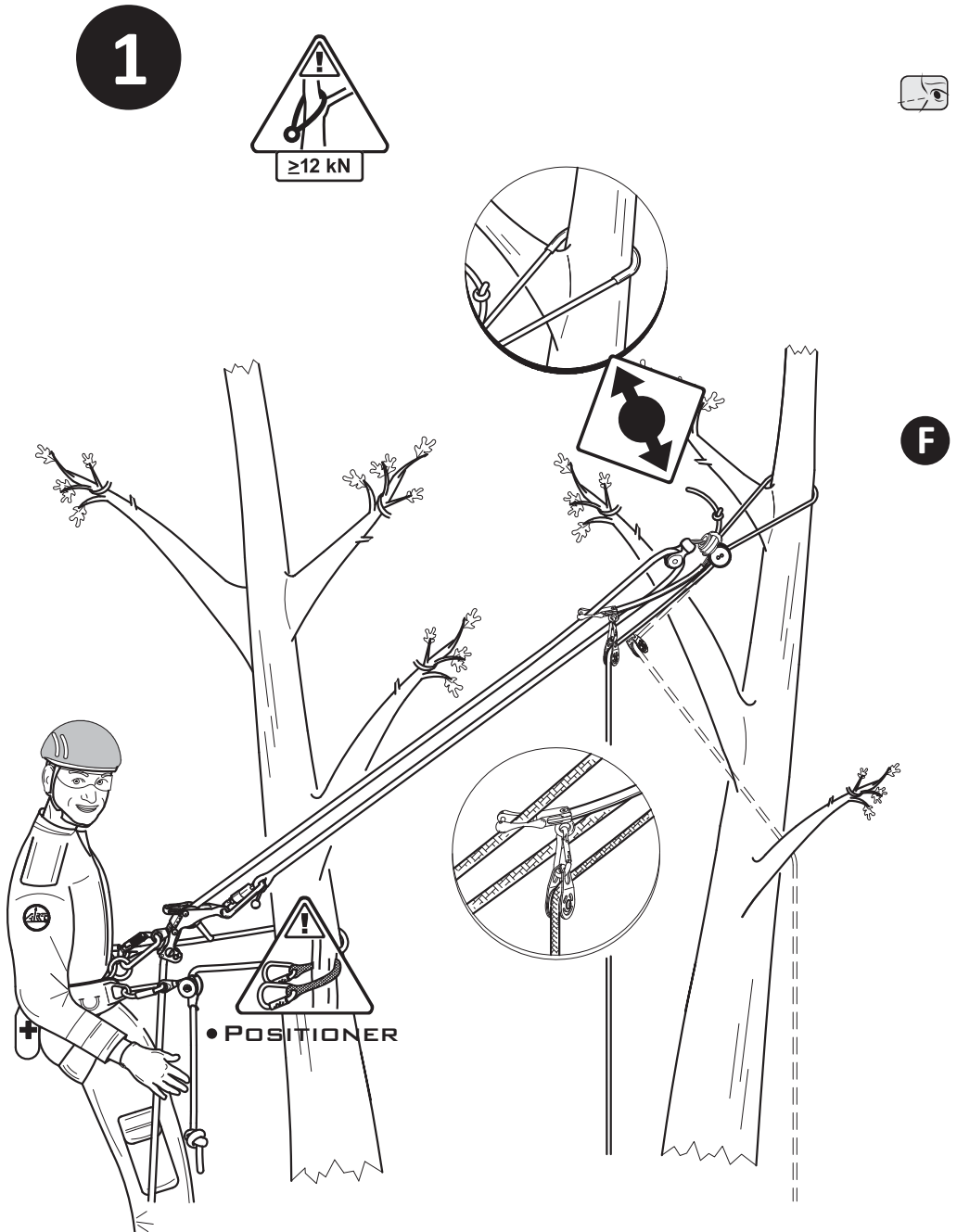

RopeGuide TwinLine:

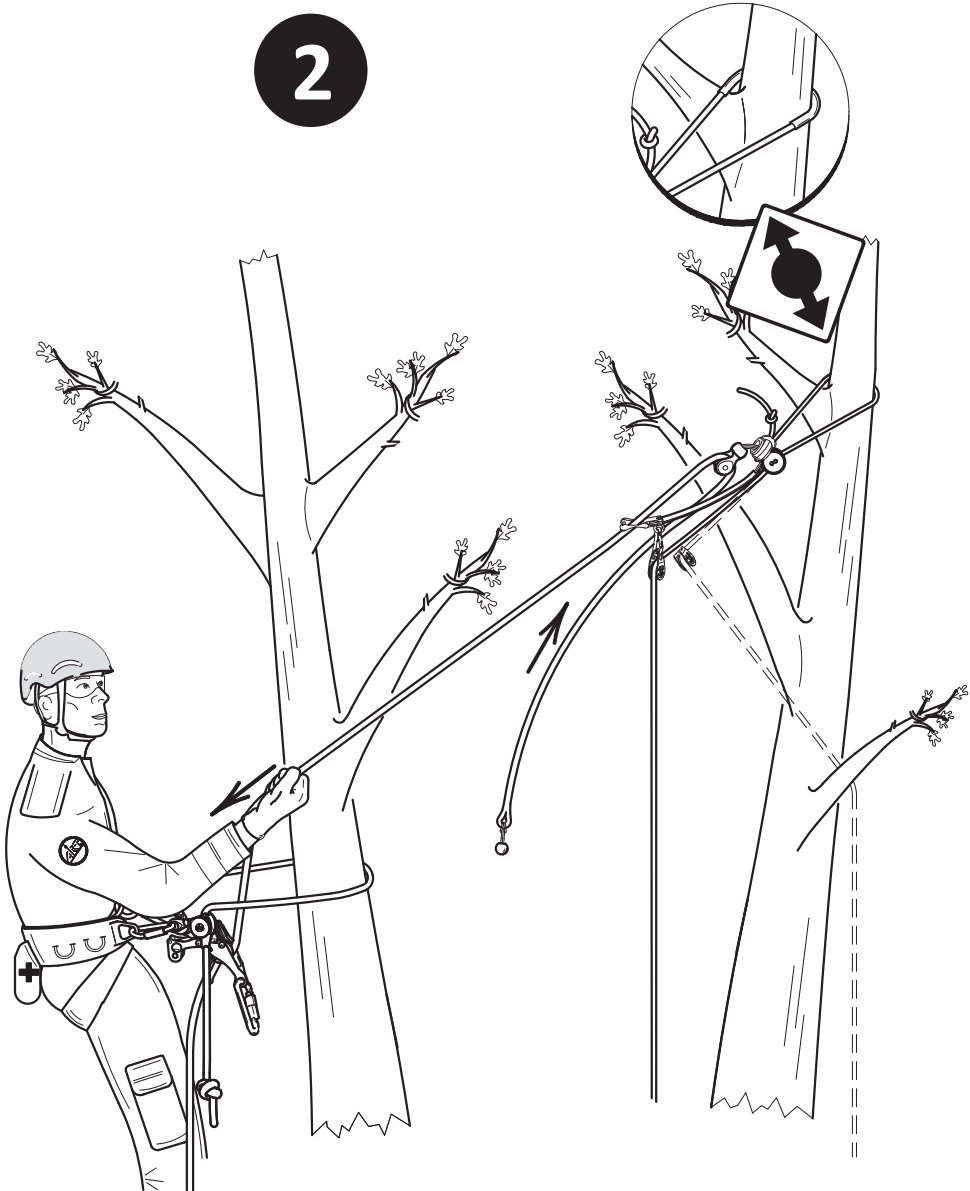

RopeGuide TwinLine:

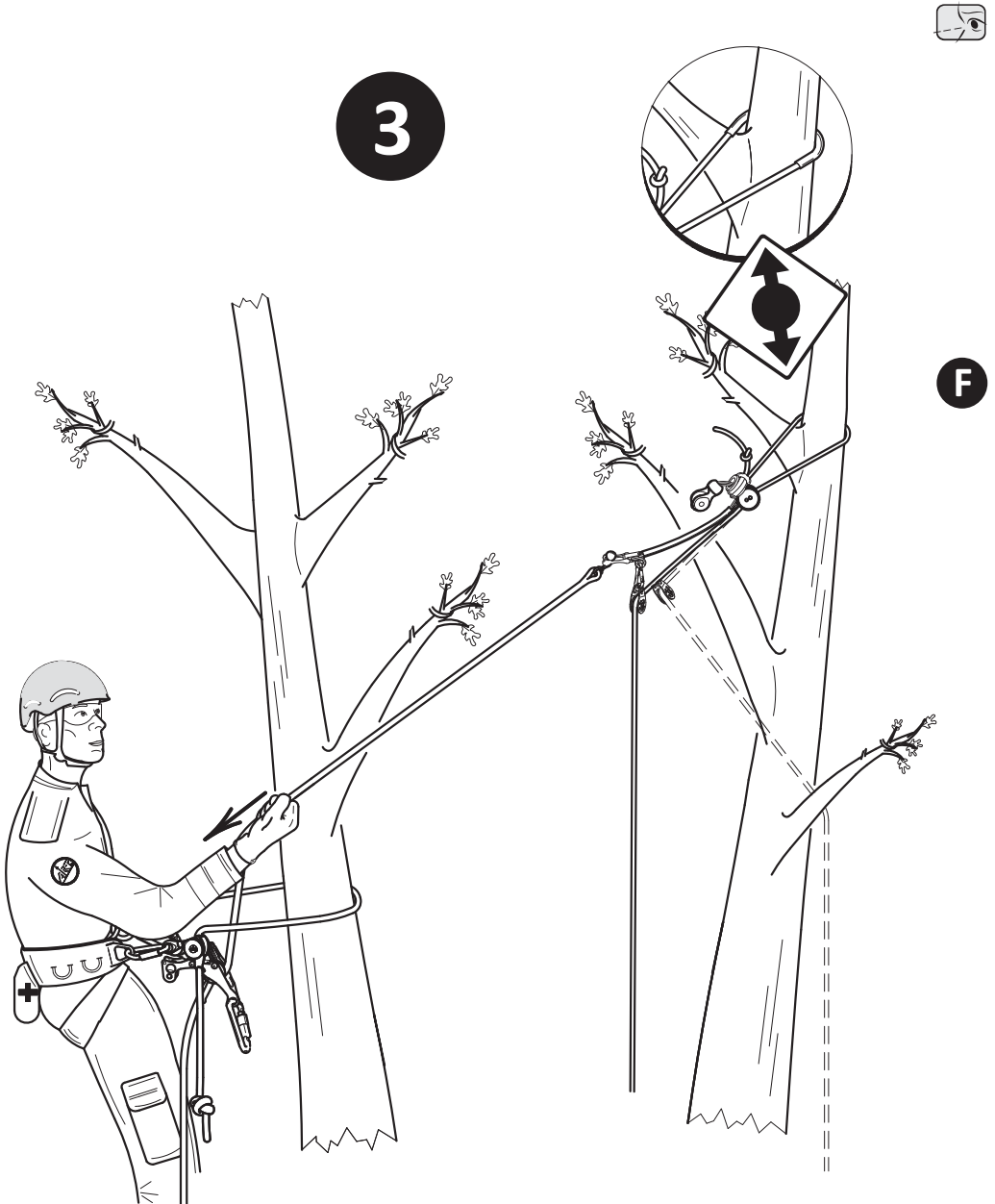

RopeGuide TwinLine:

4

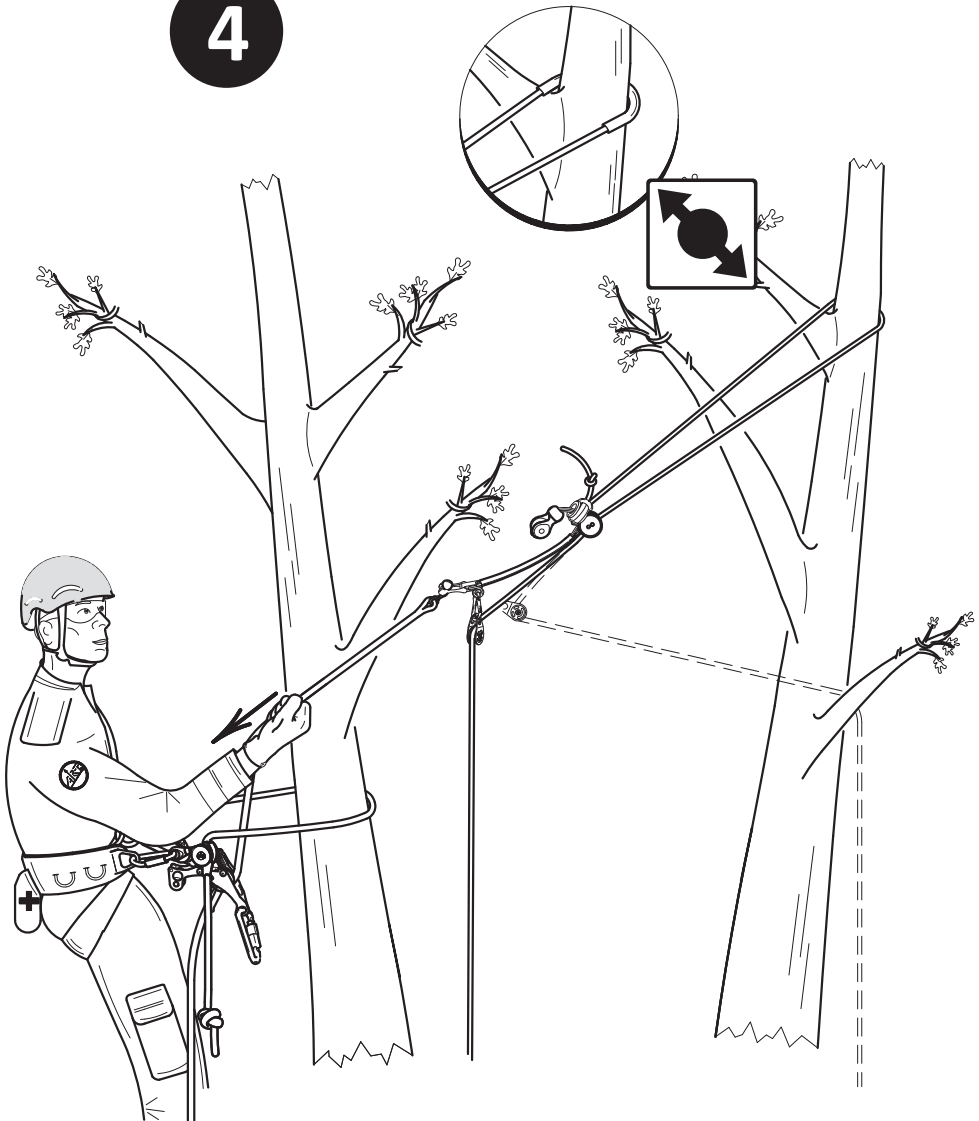

RopeGuide TwinLine:



5

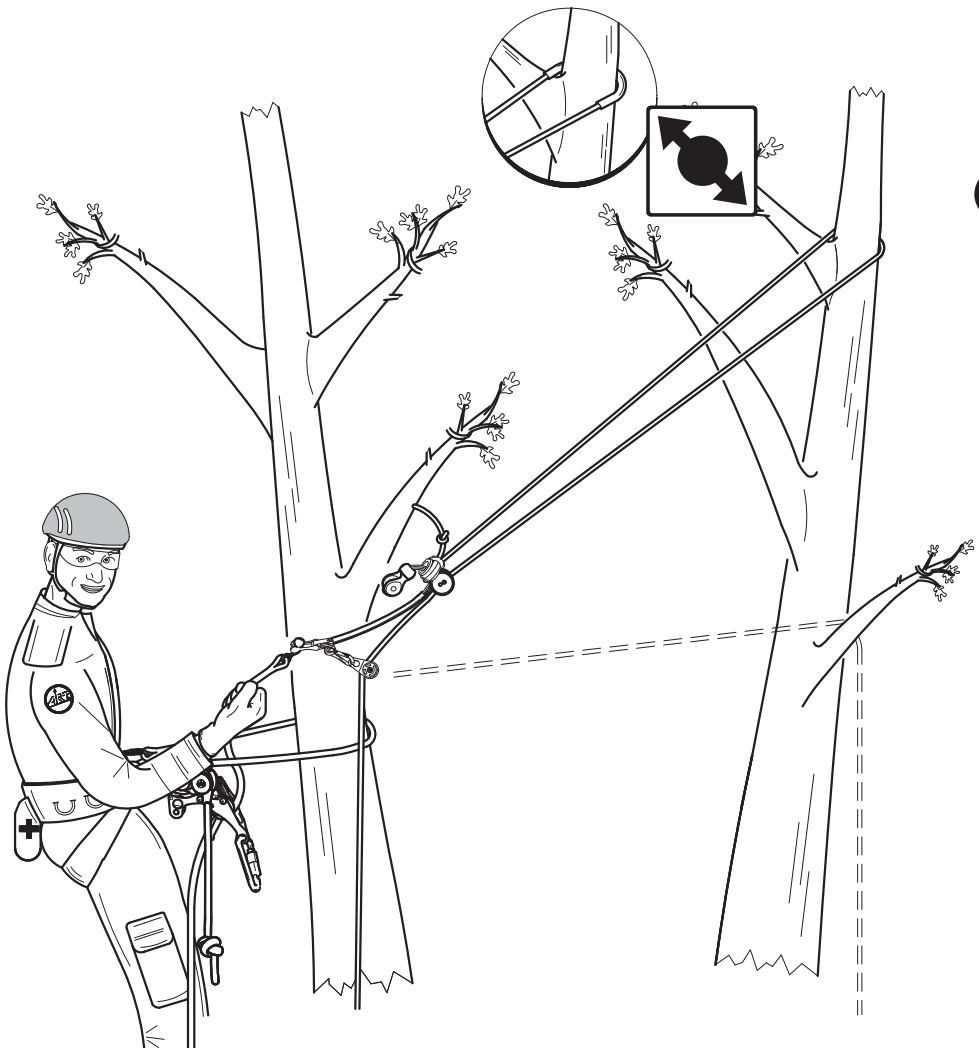

F

RopeGuide TwinLine:

6

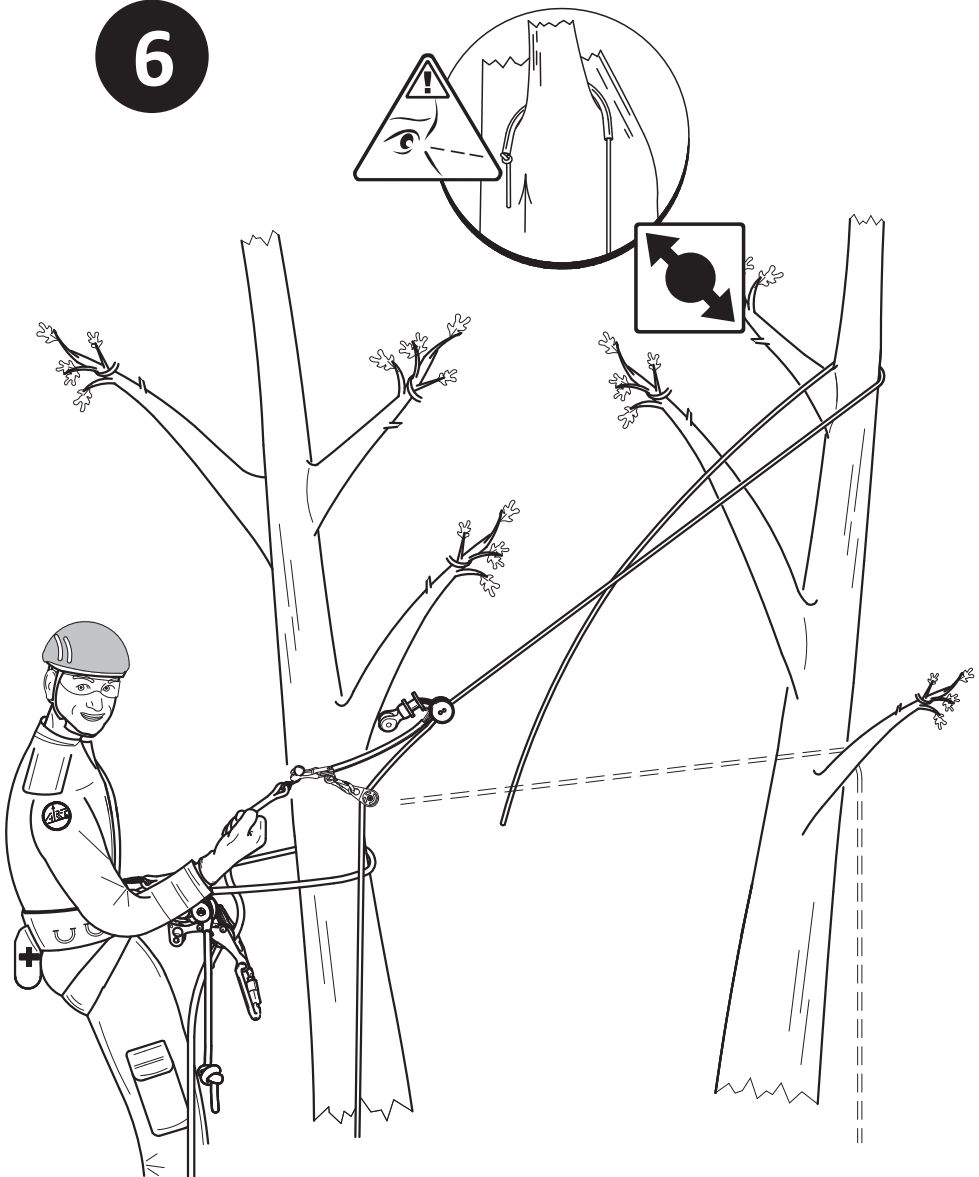

RopeGuide TwinLine:



7

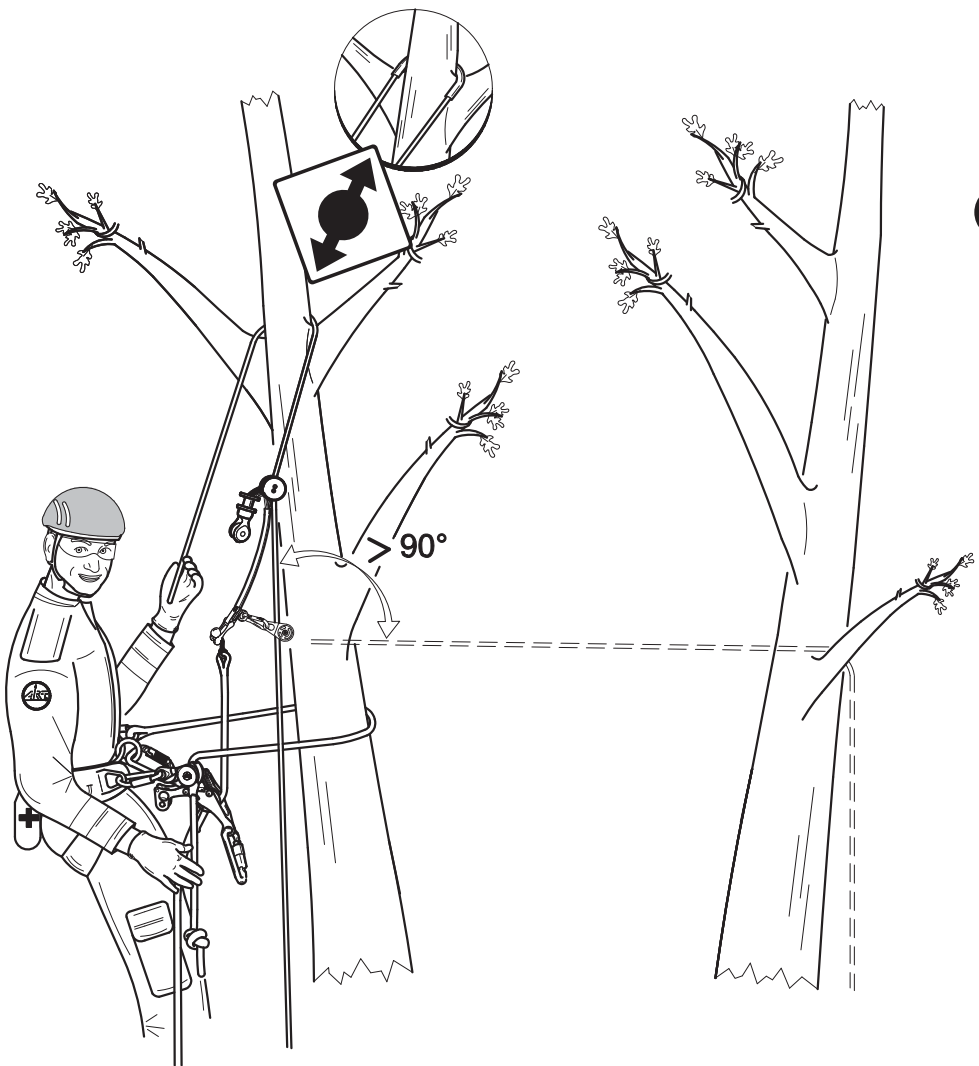

F

RopeGuide TwinLine:

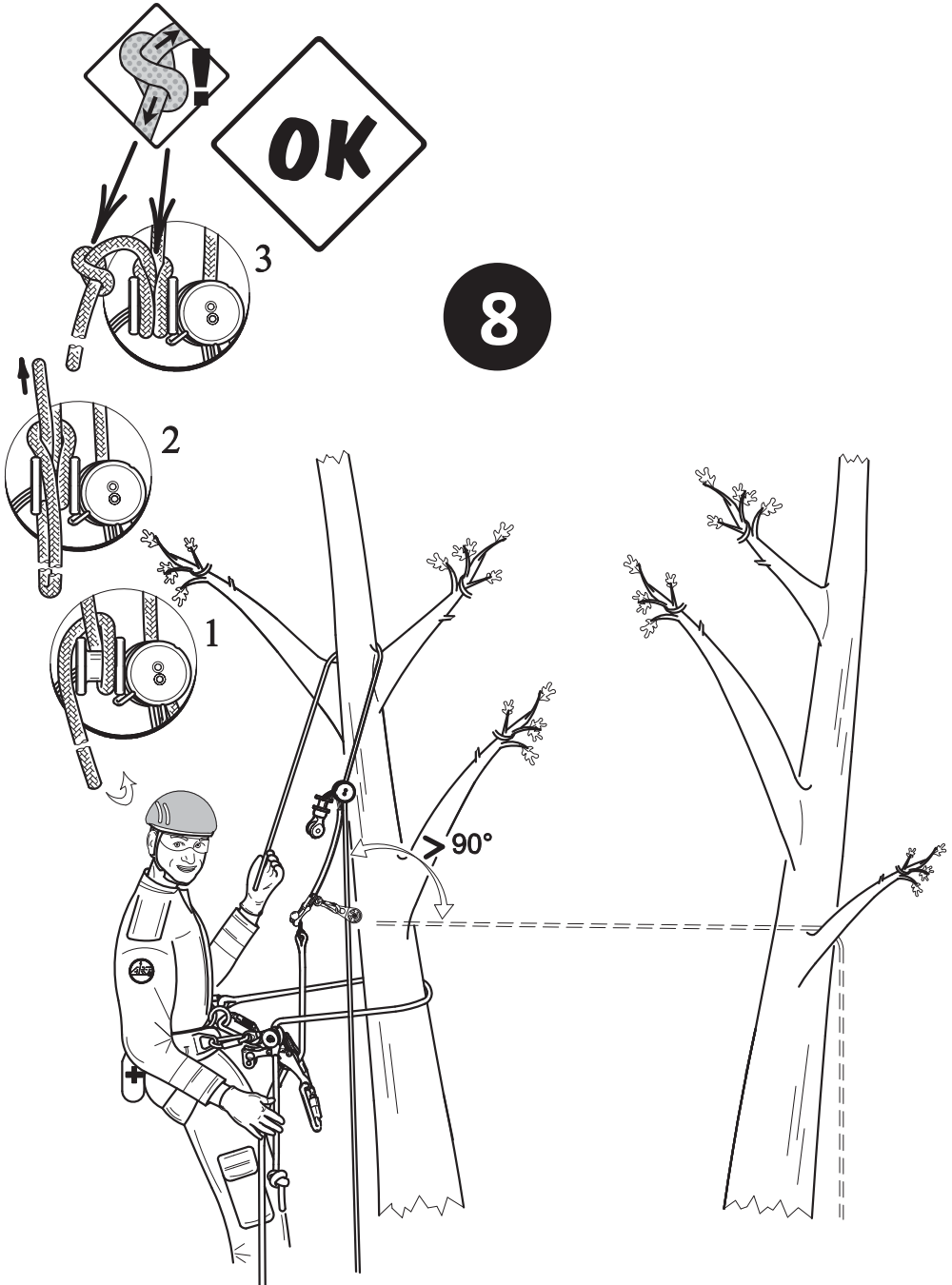

RopeGuide TwinLine:



9

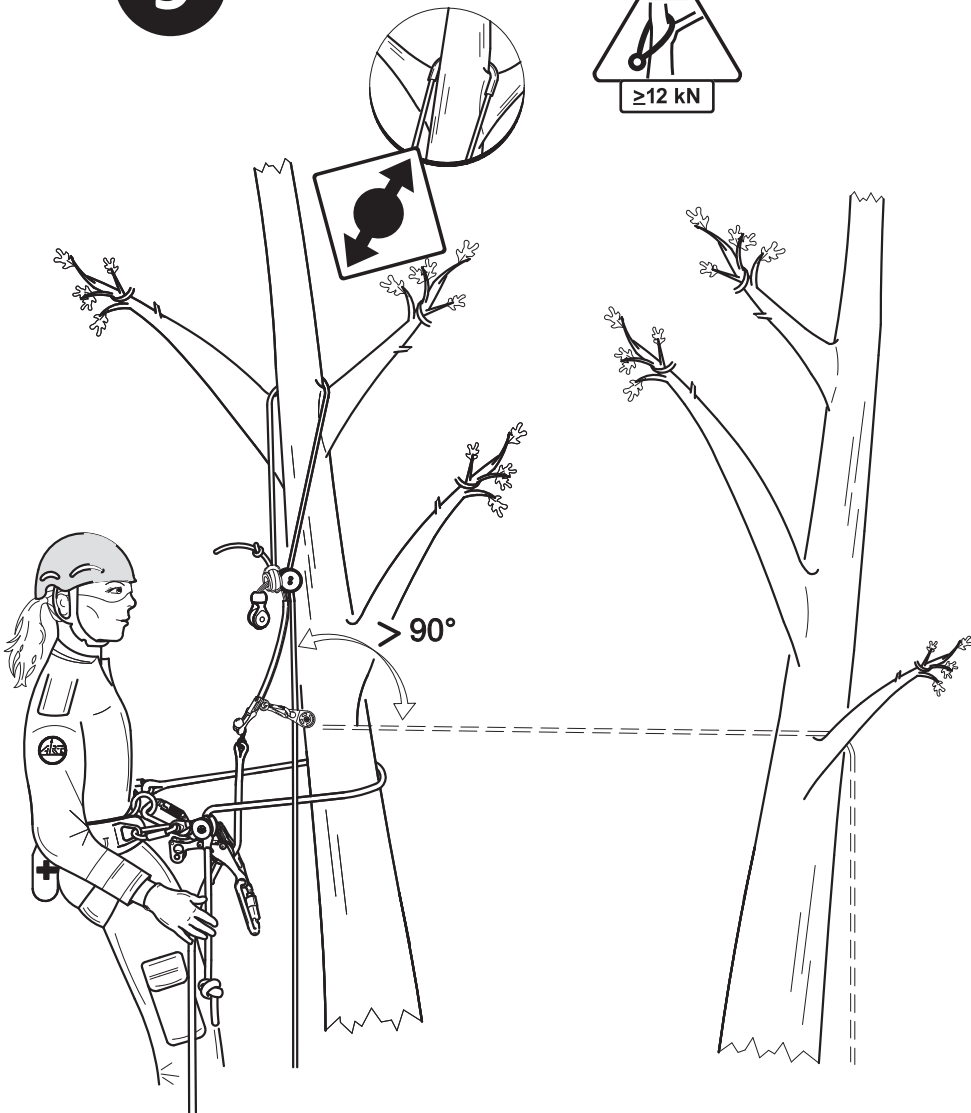

RopeGuide TwinLine:

10

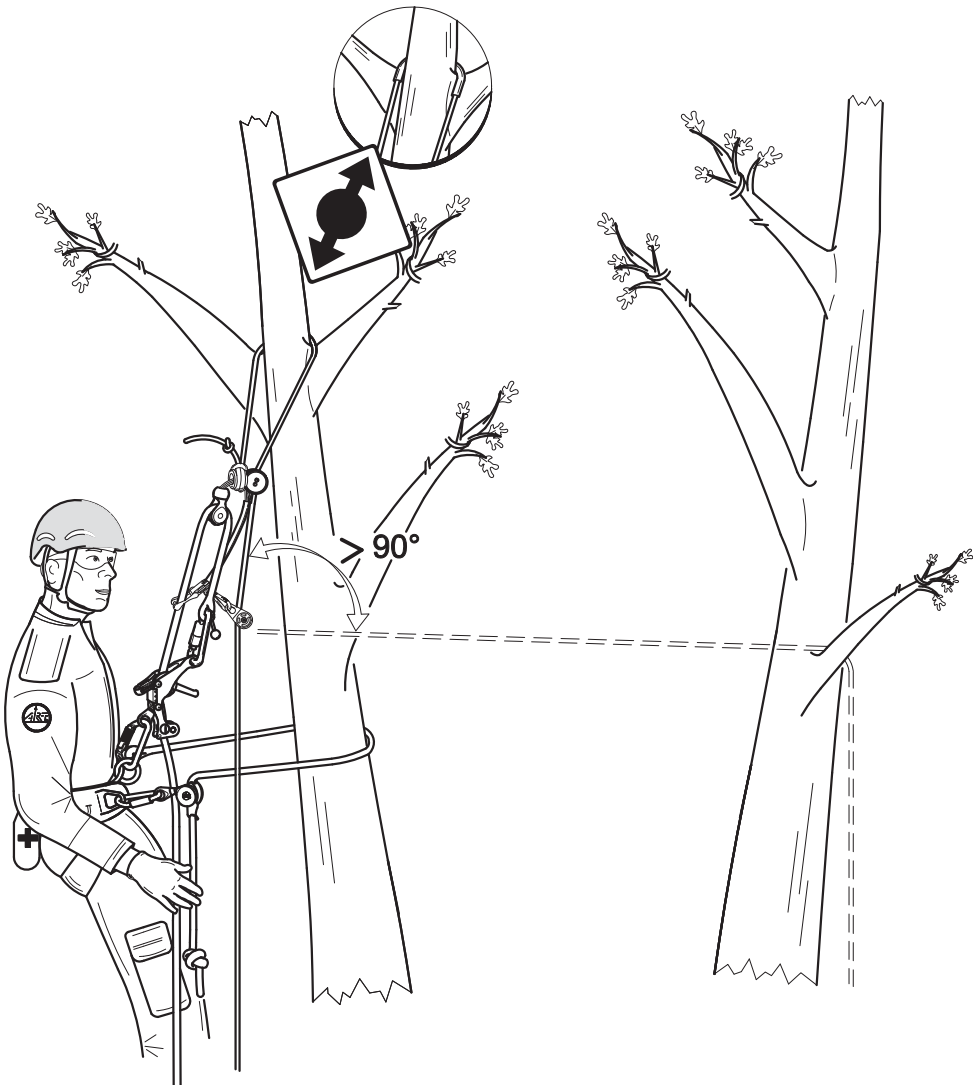

RopeGuide TwinLine:

11

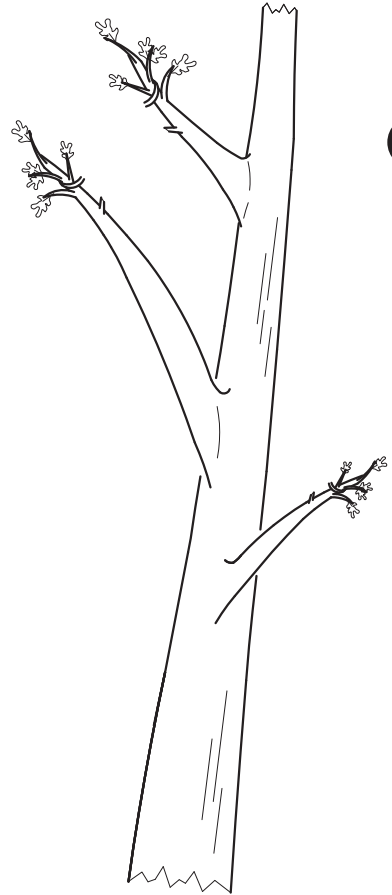
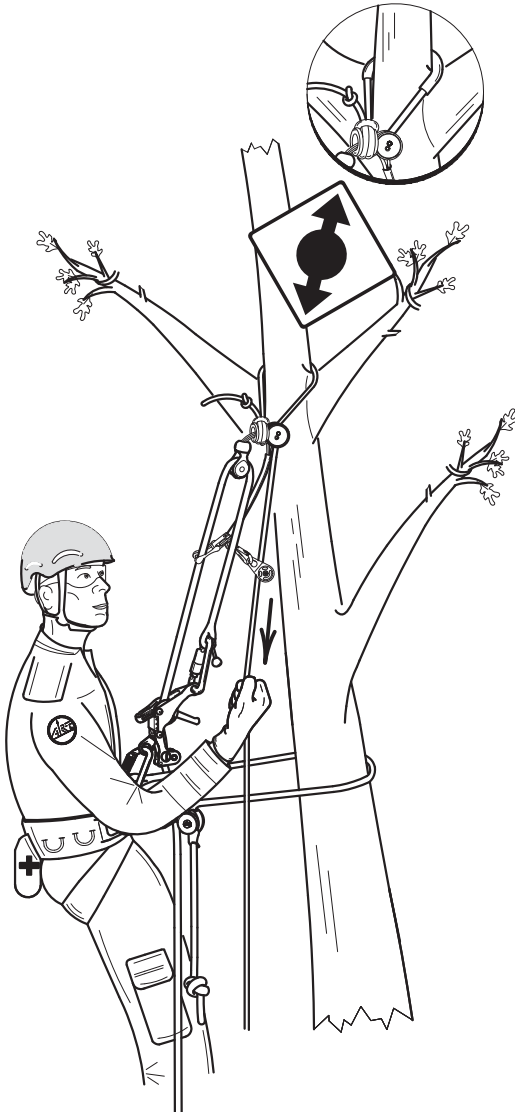

F

RopeGuide TwinLine:

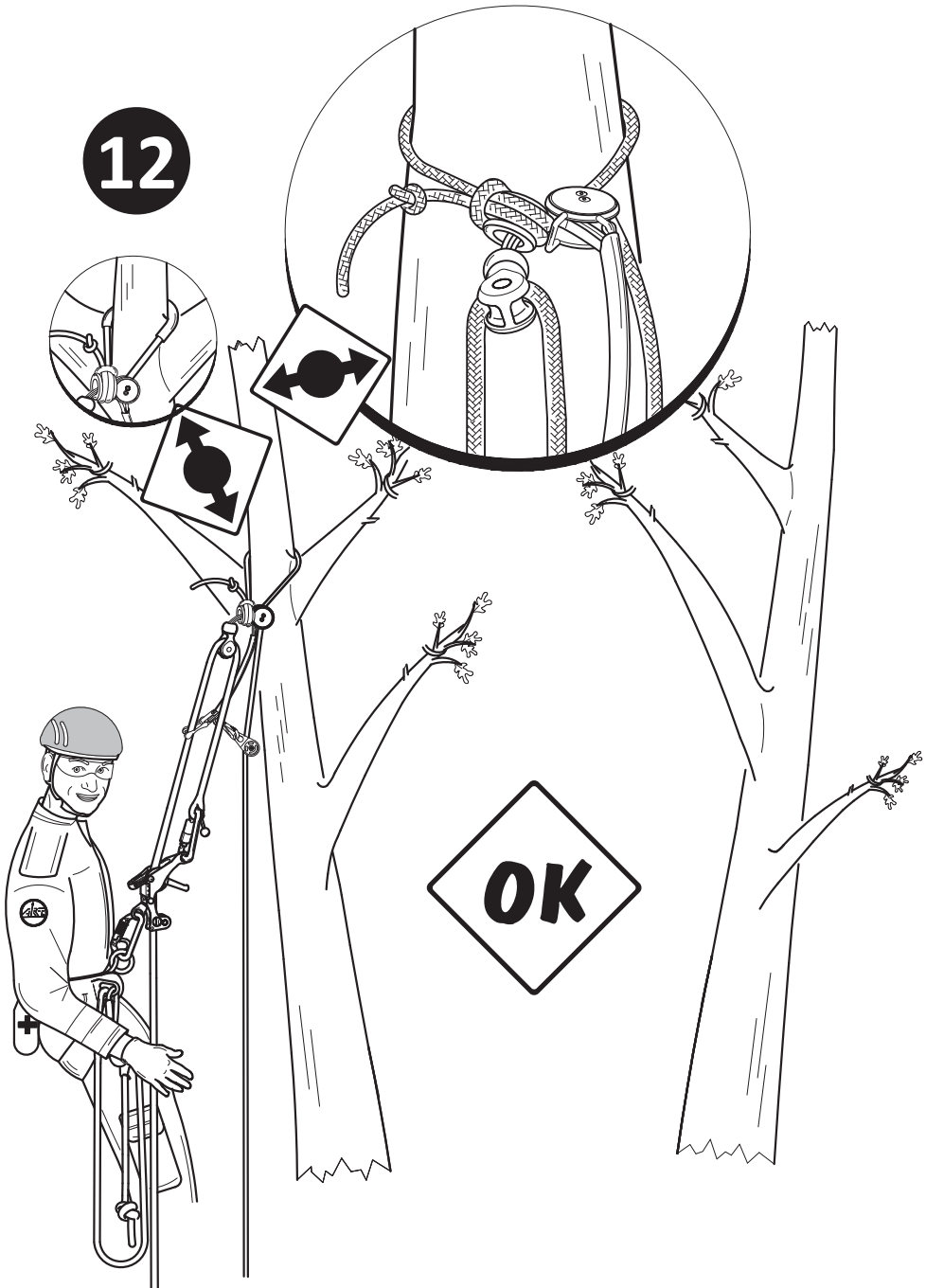

RopeGuide TwinLine:

1

• STOPPERGATE

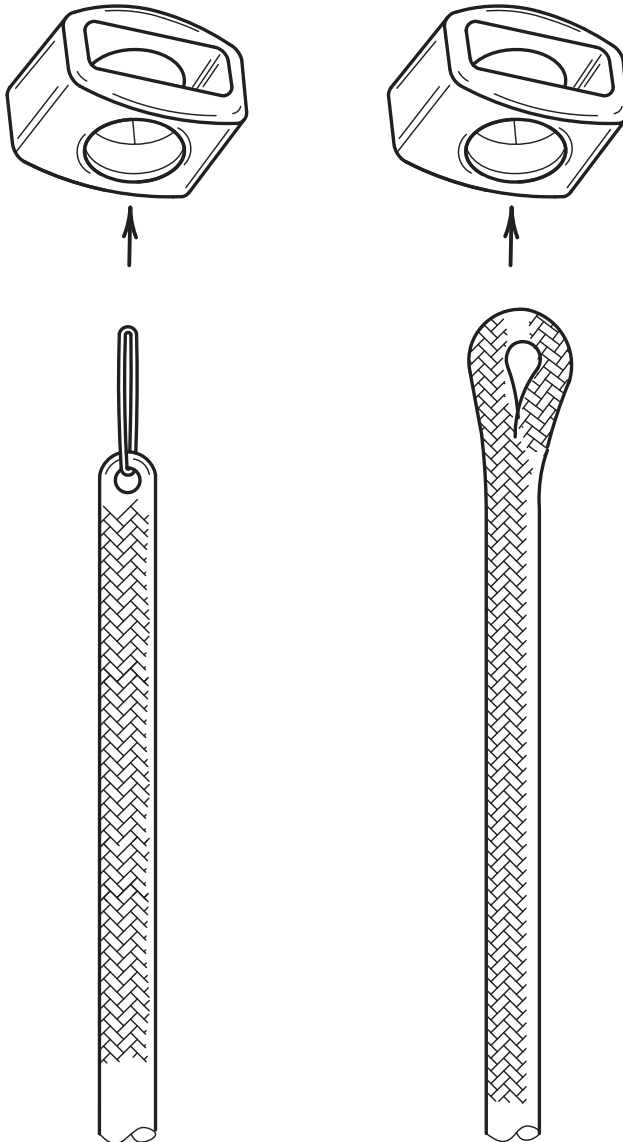

G

RopeGuide TwinLine:

2

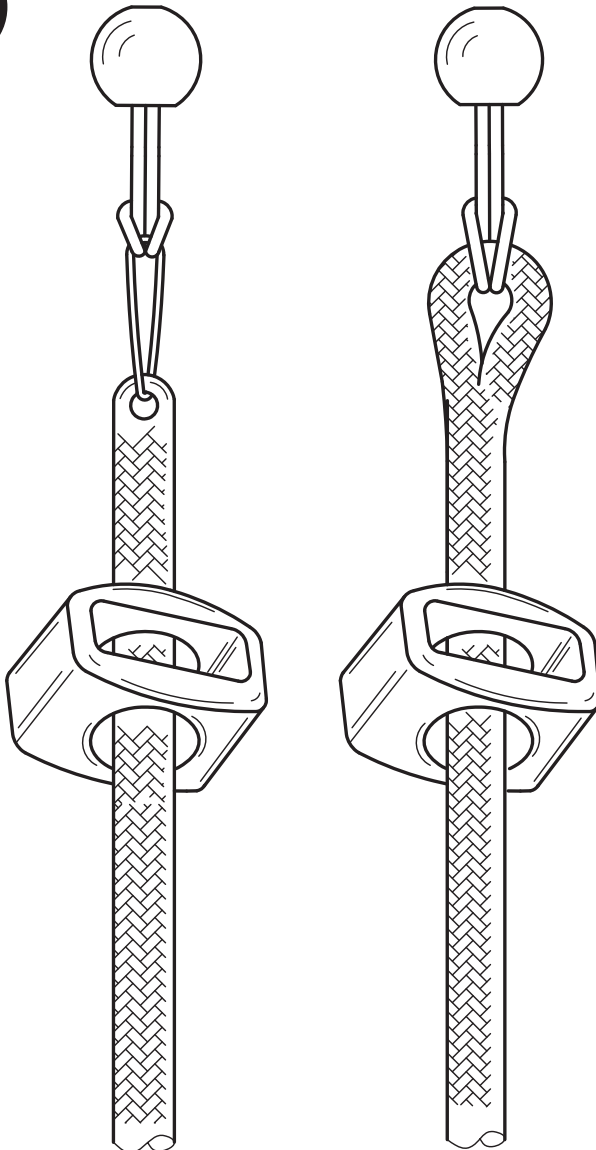

RopeGuide TwinLine:

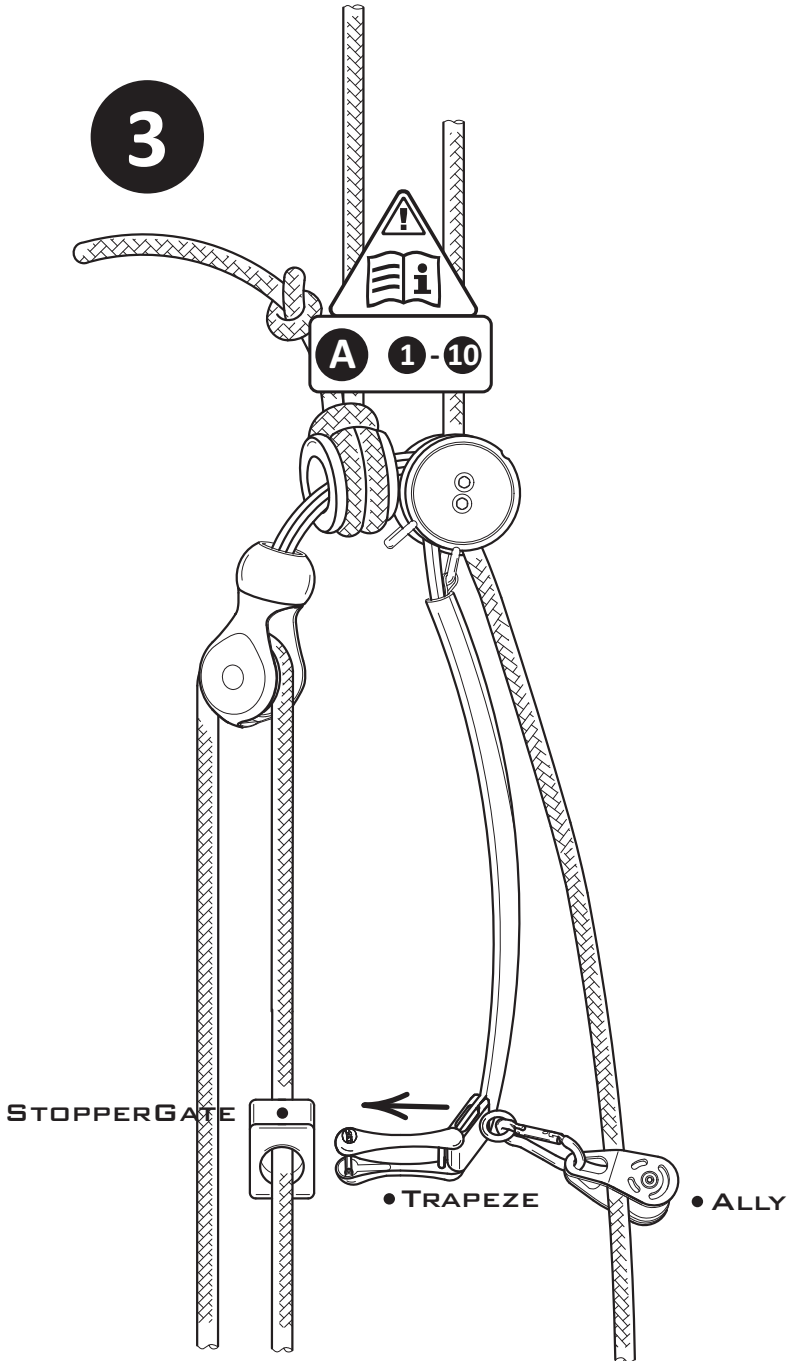

RopeGuide TwinLine:

4

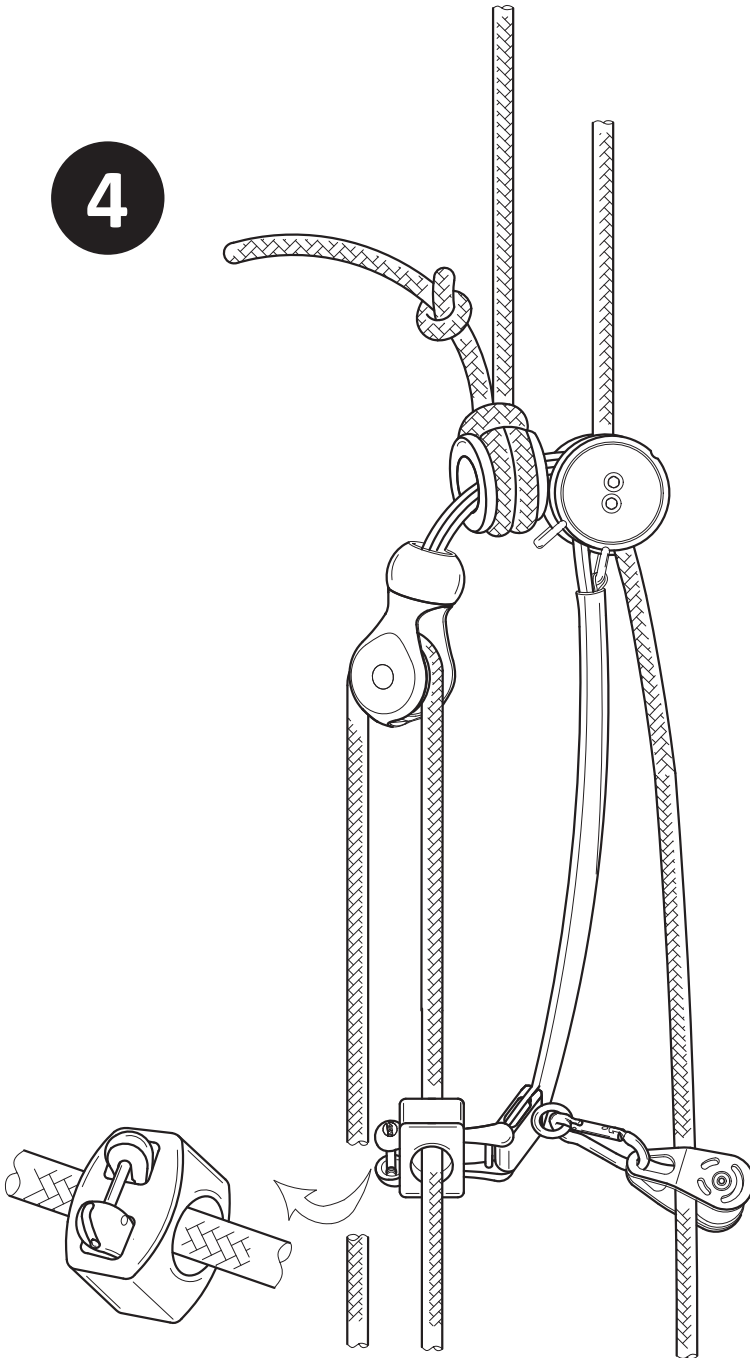

RopeGuide TwinLine:

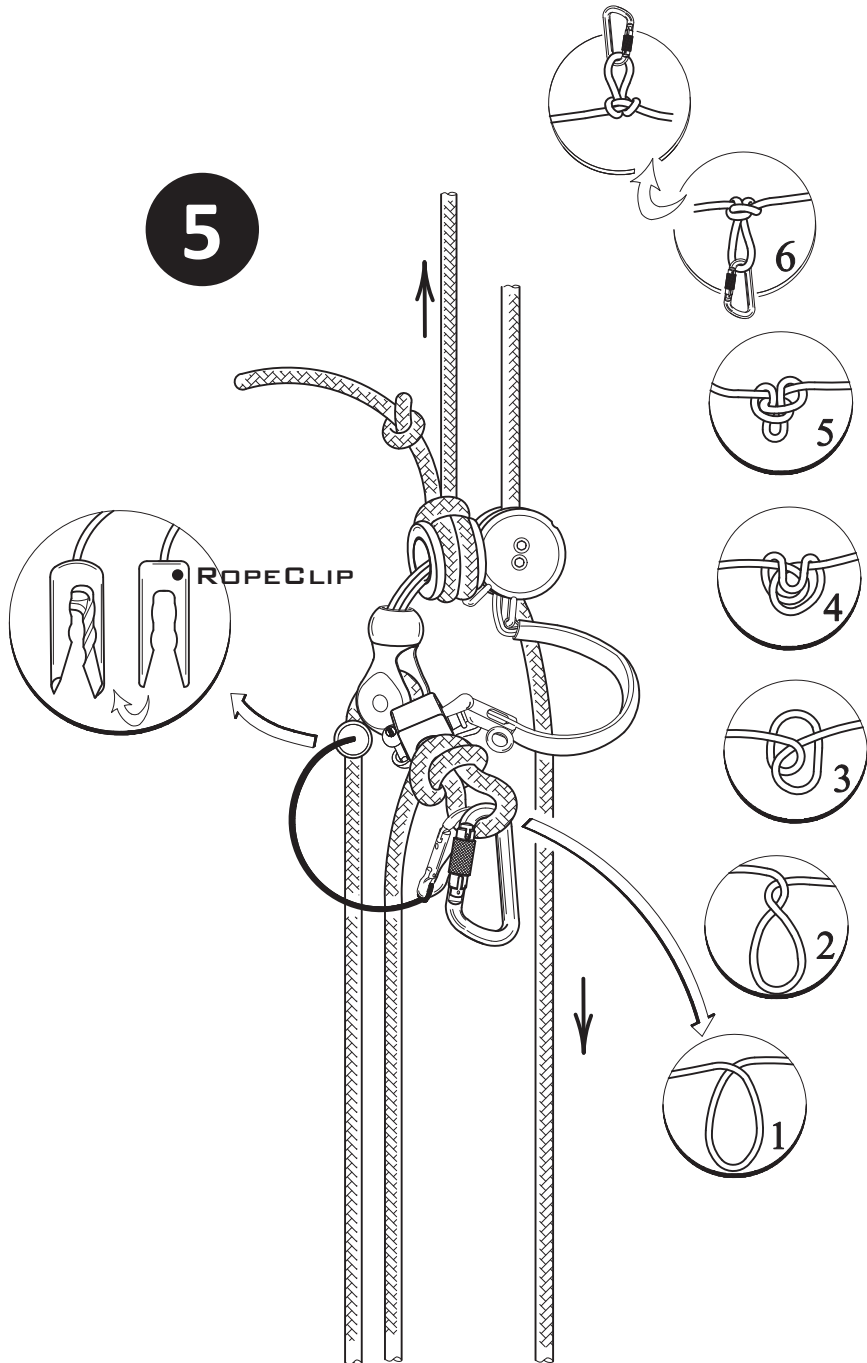

RopeGuide TwinLine:

6

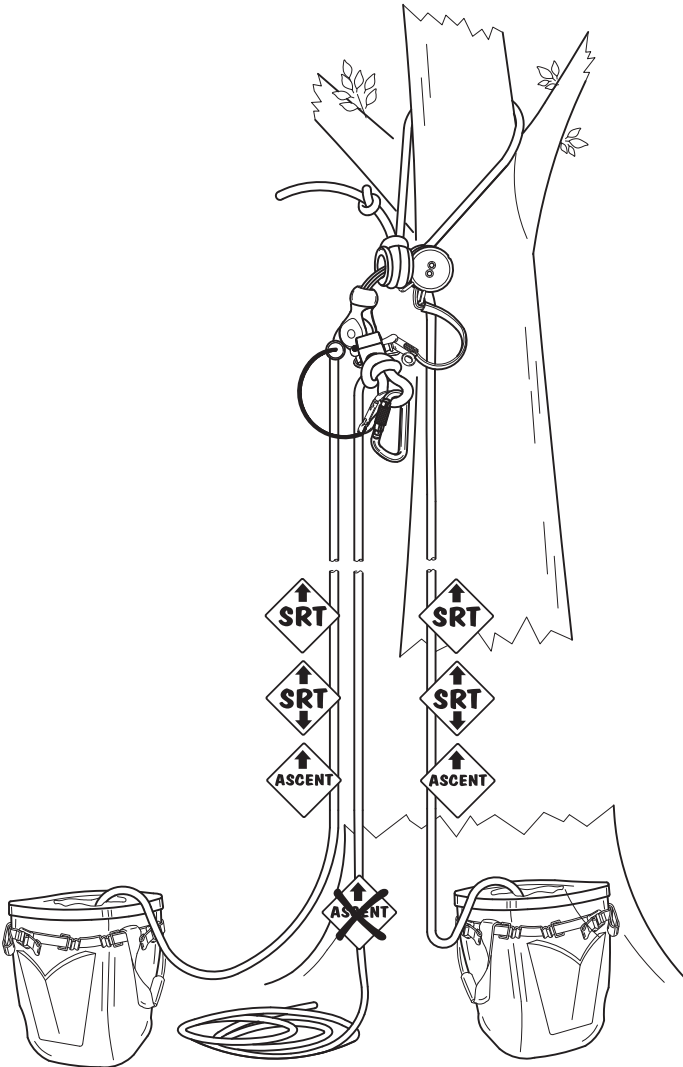
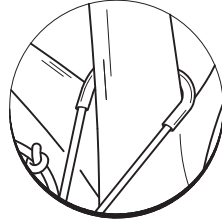

RopeGuide TwinLine:

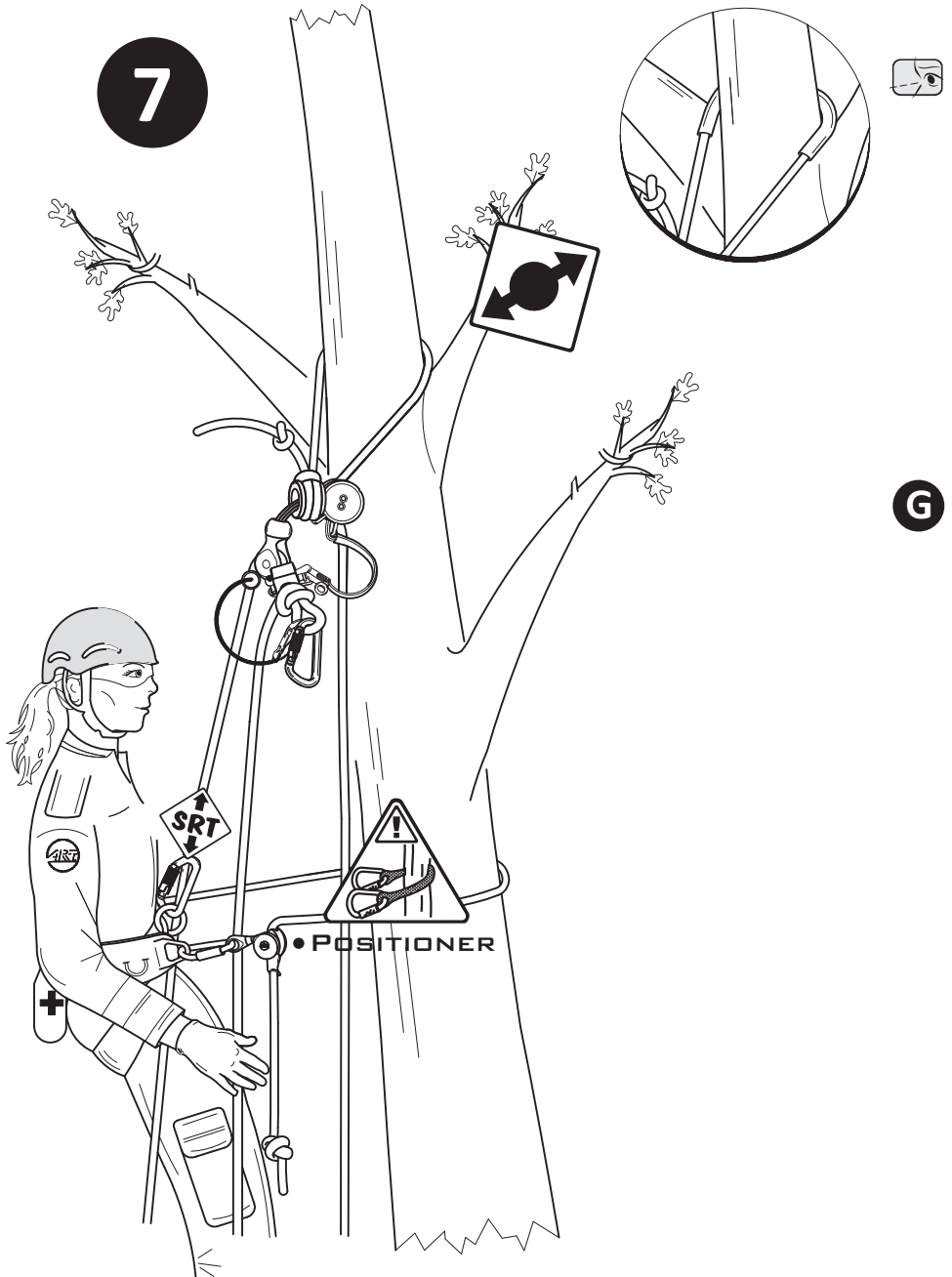

RopeGuide TwinLine:

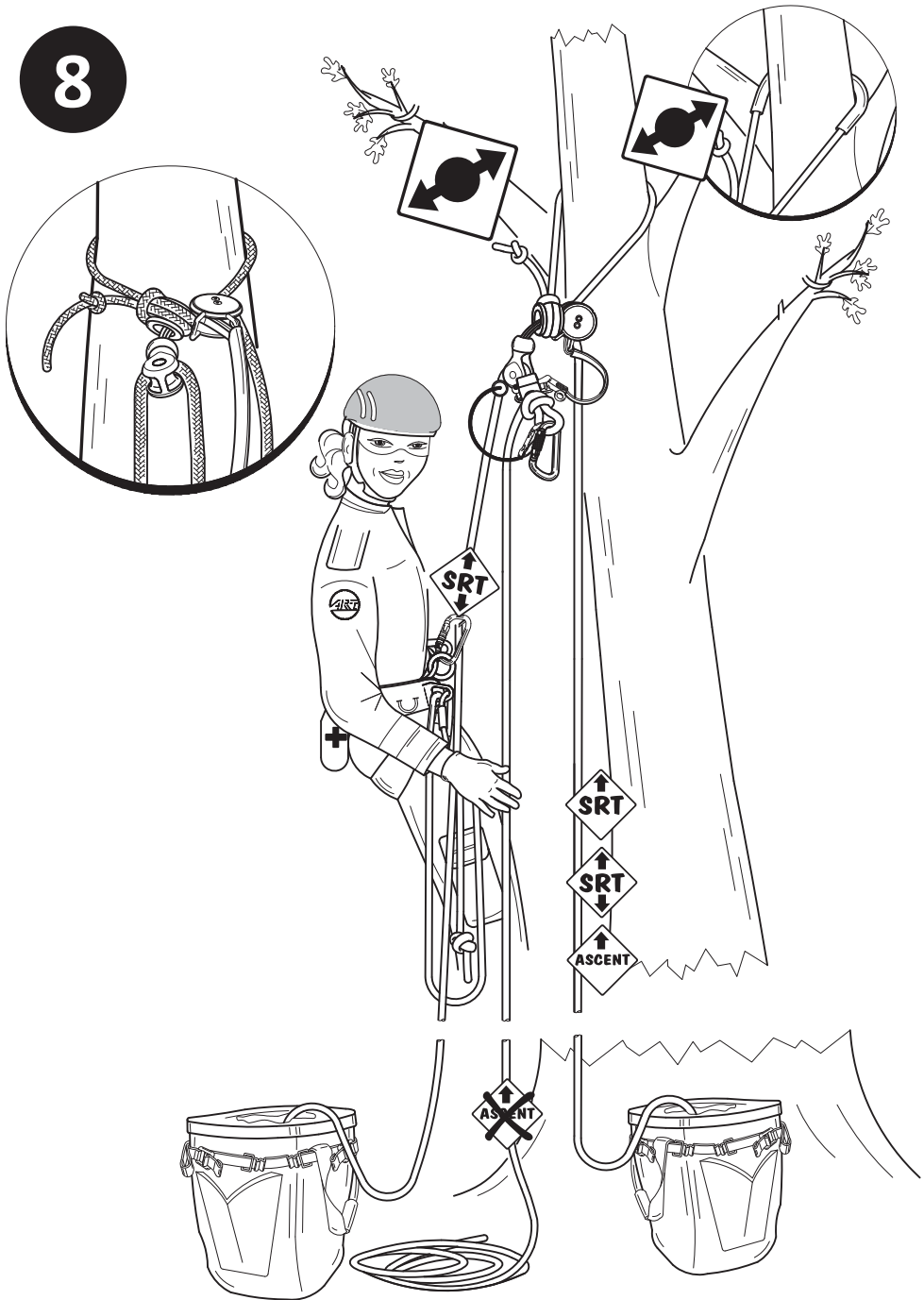

RopeGuide TwinLine:

1

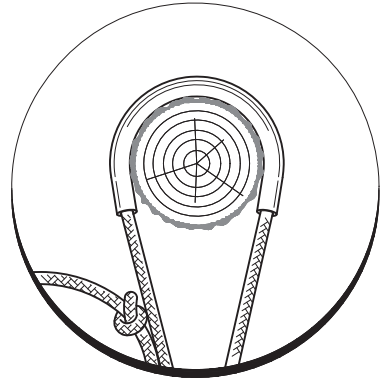
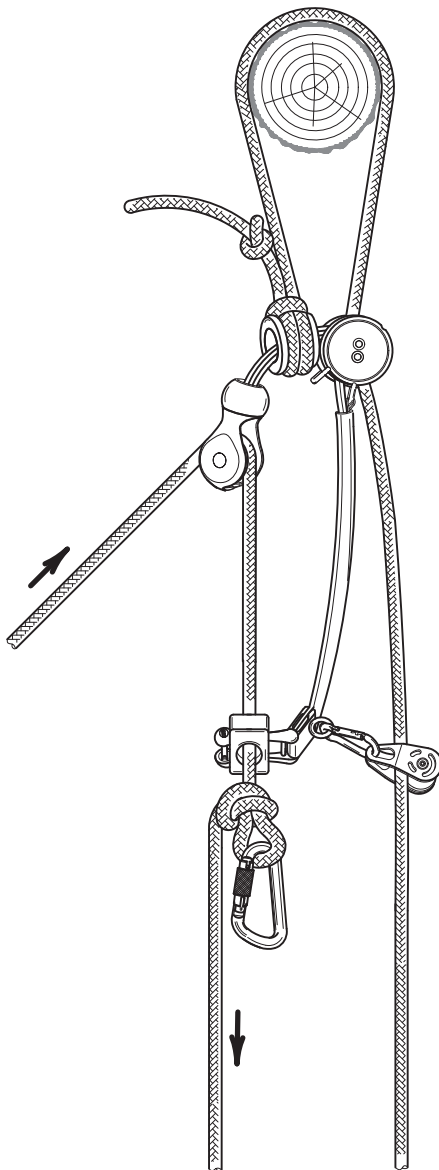

H

RopeGuide TwinLine:

2

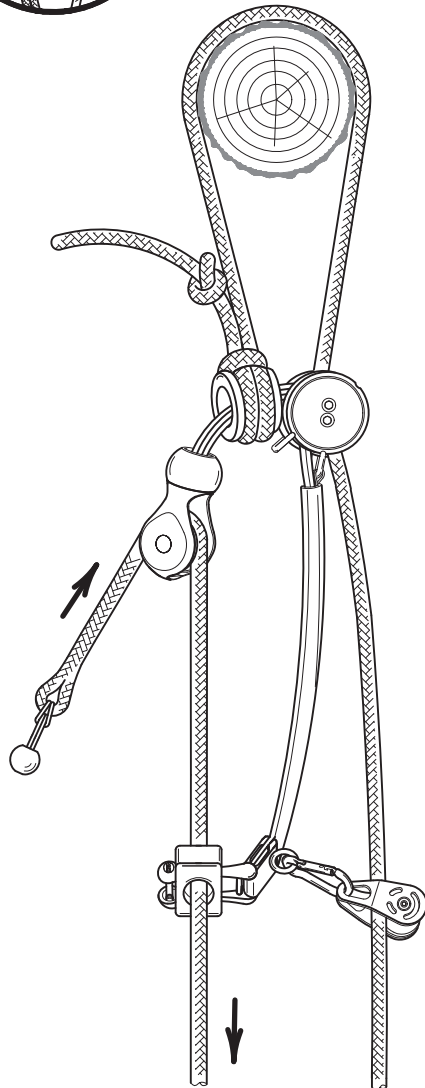
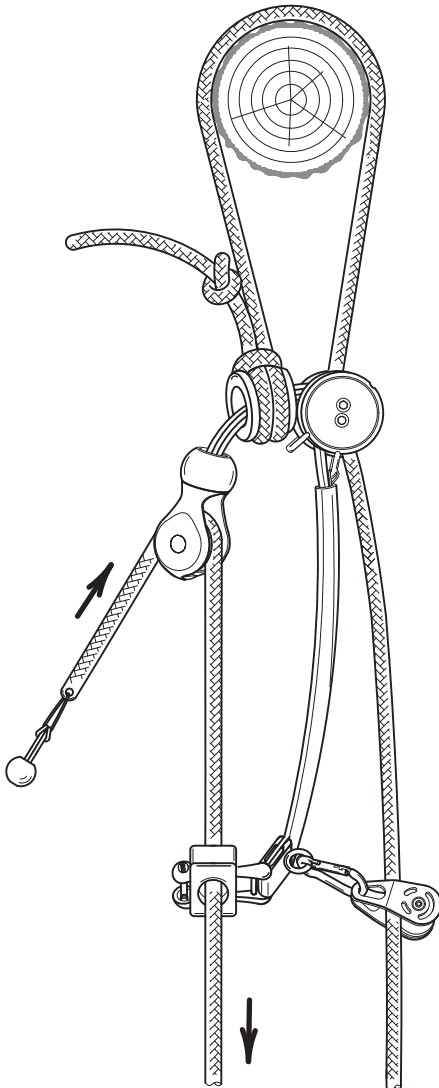
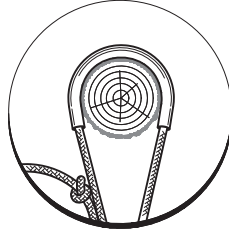

RopeGuide TwinLine:

3

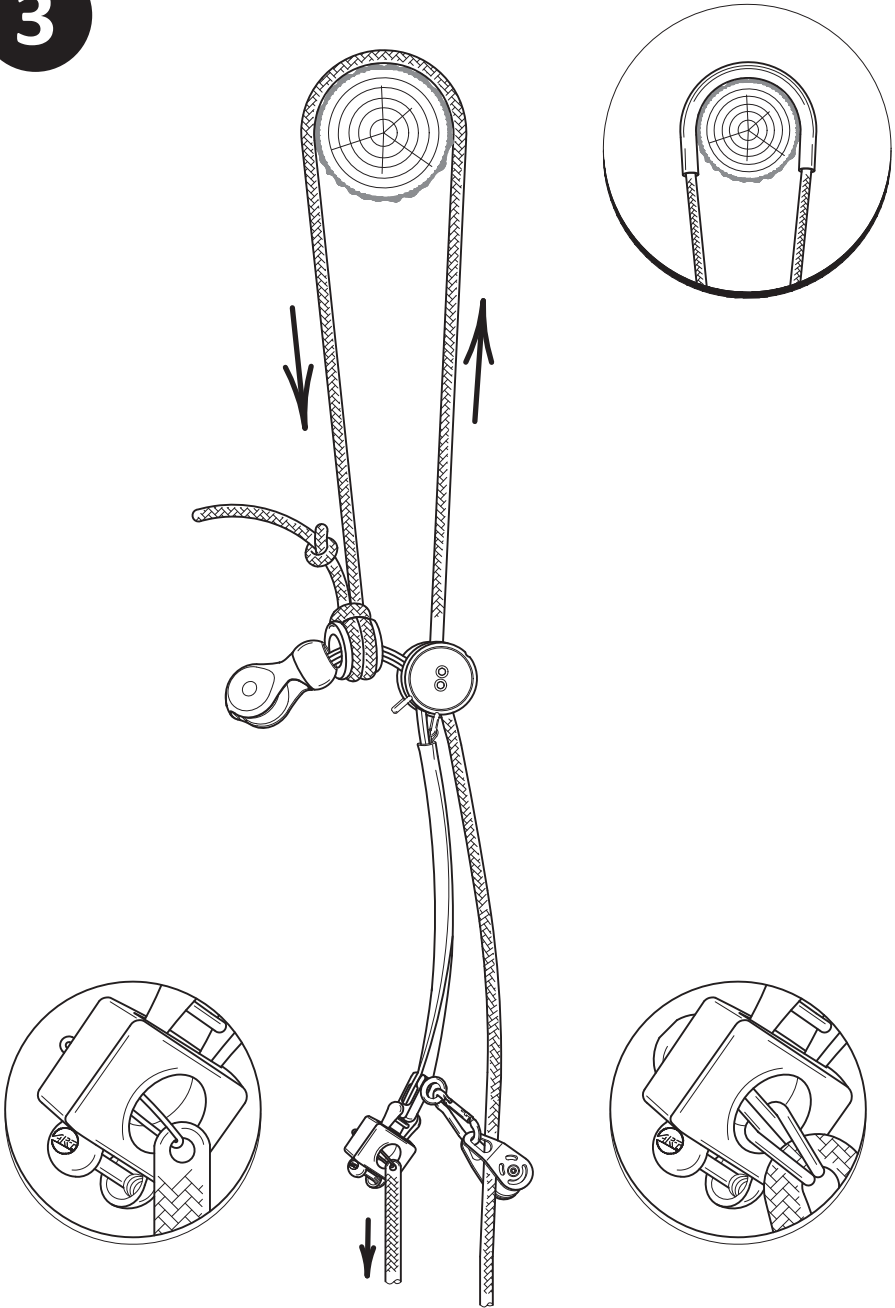

H

RopeGuide TwinLine:

4

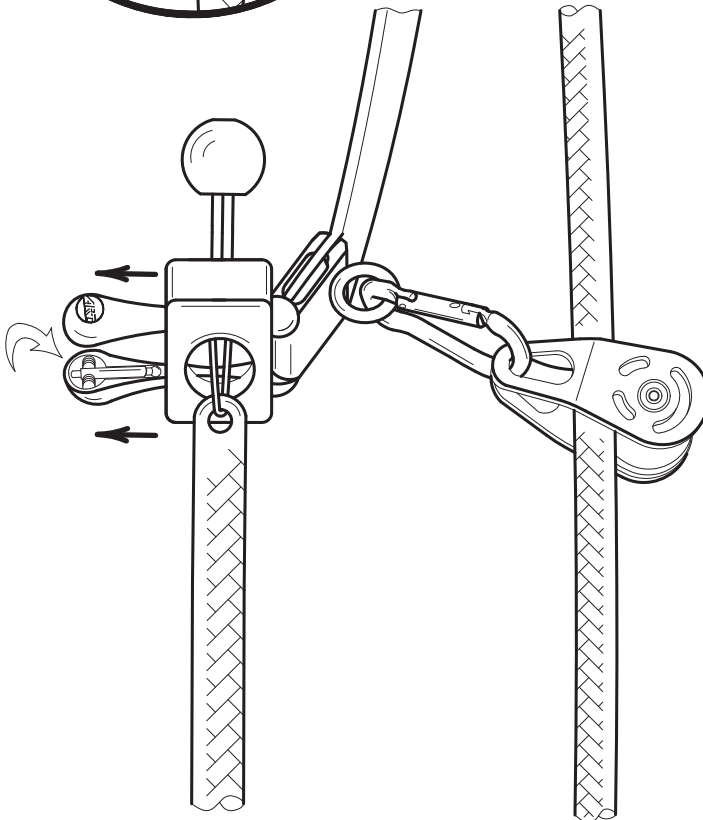
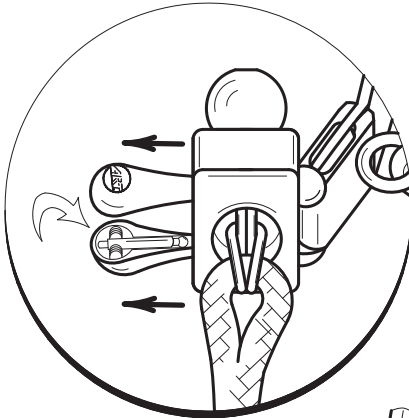

RopeGuide TwinLine:

5

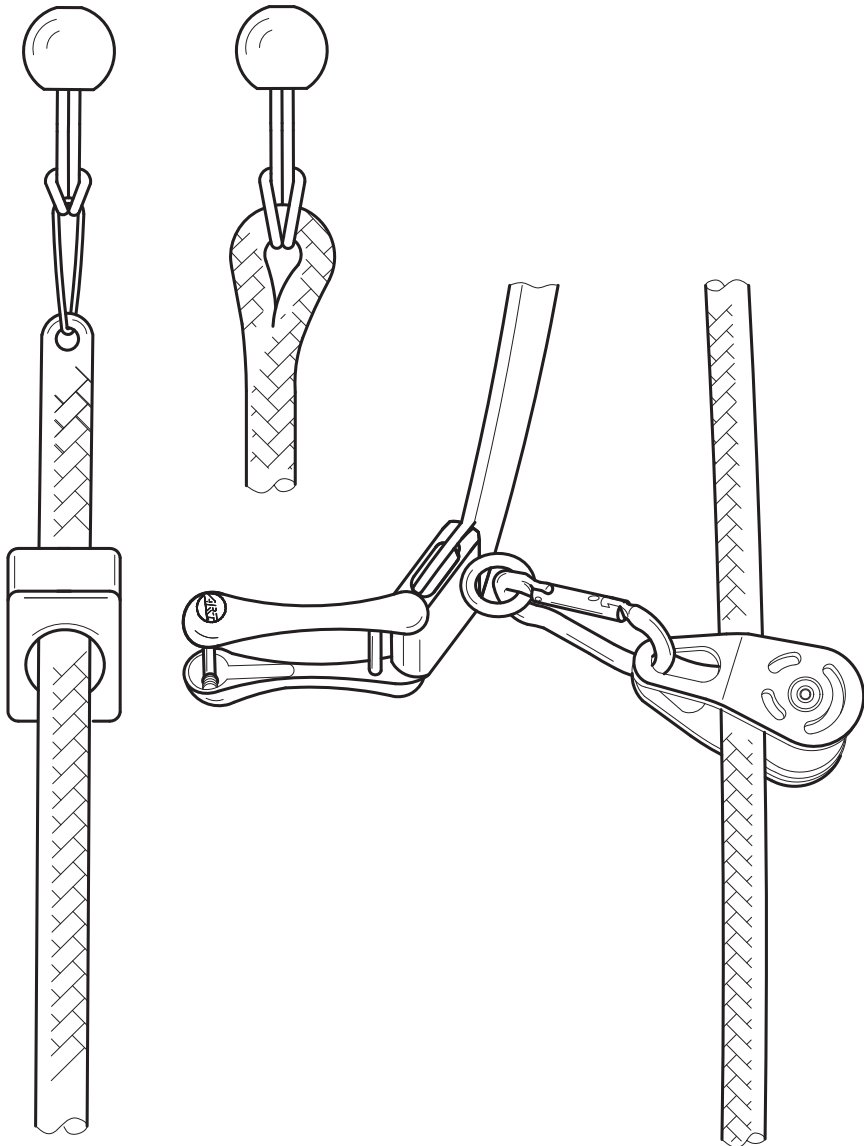

H

RopeGuide TwinLine:

6

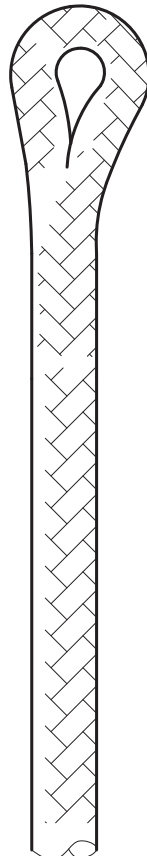
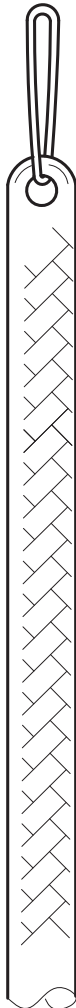
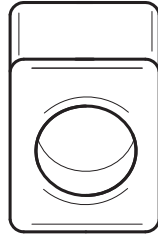
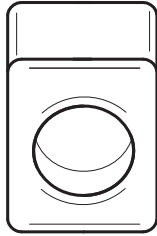

RopeGuide TwinLine:

1

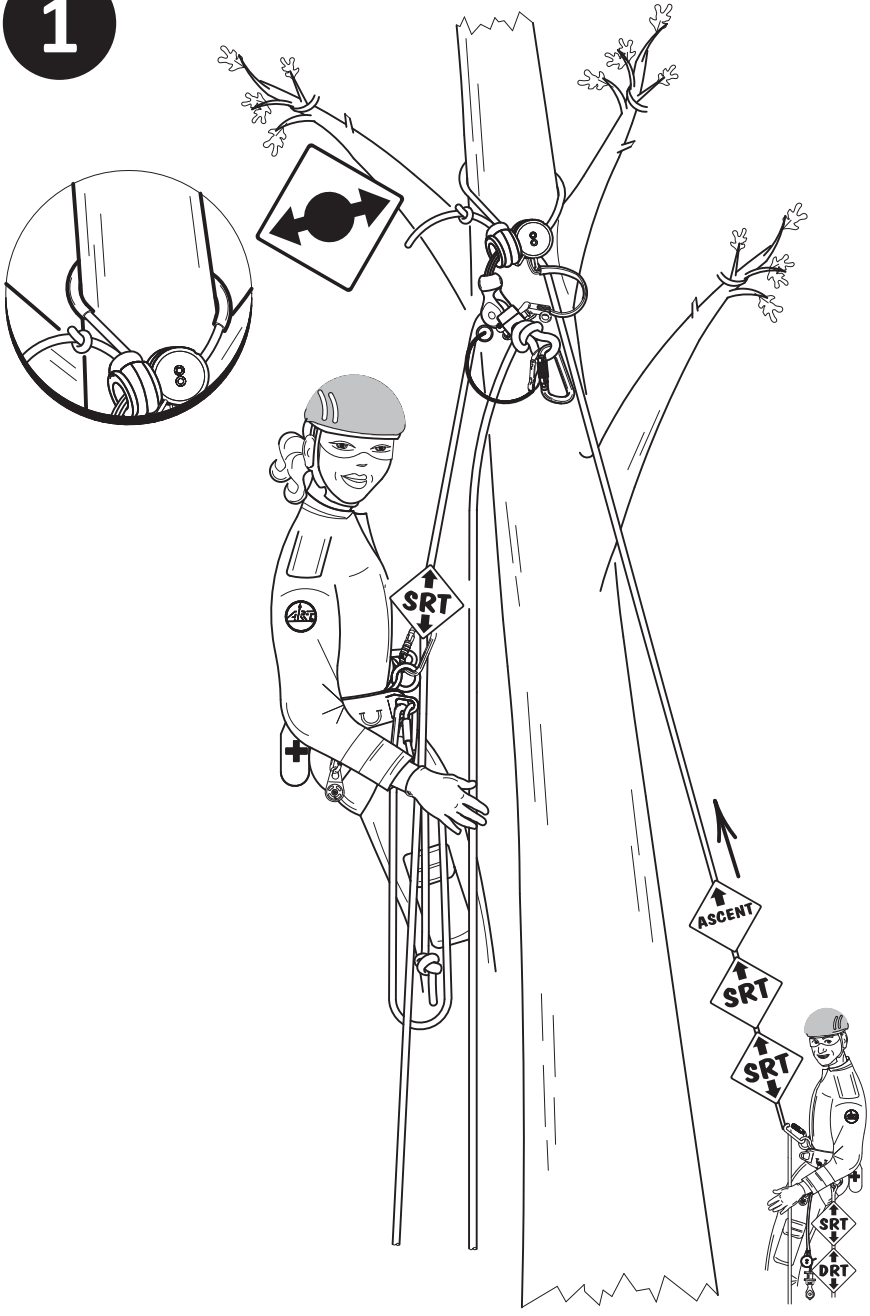

I

RopeGuide TwinLine:

2

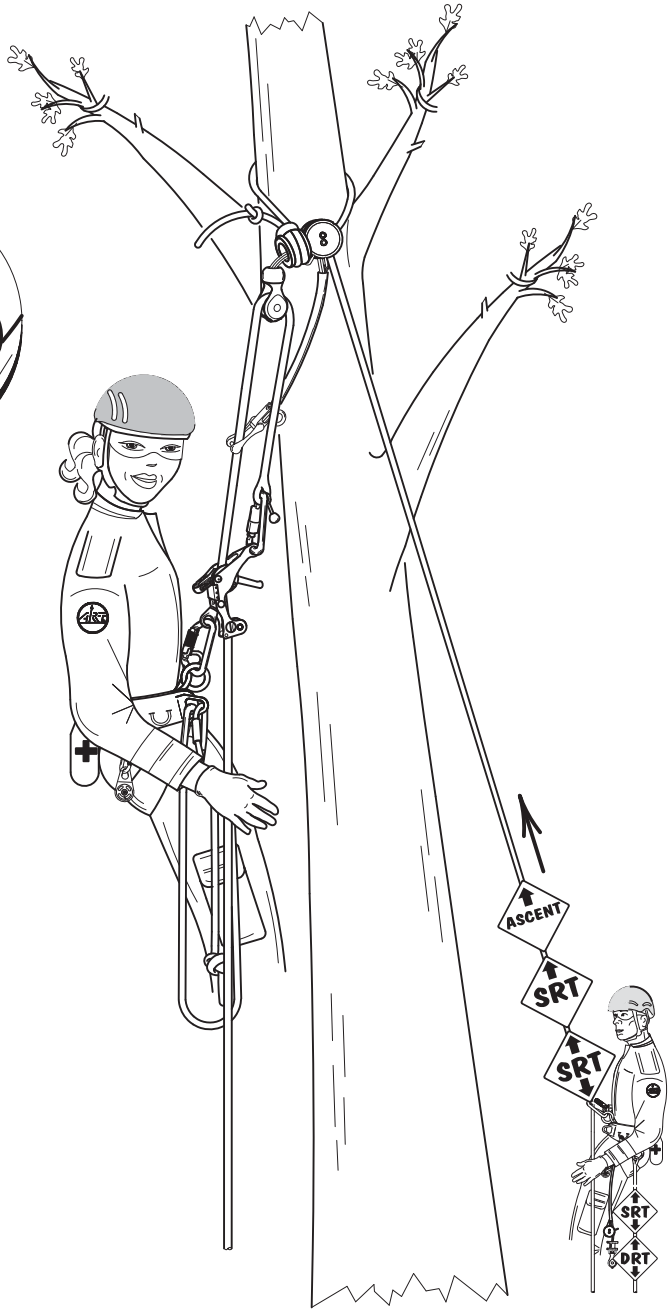
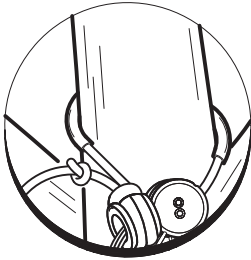

RopeGuide TwinLine:

3

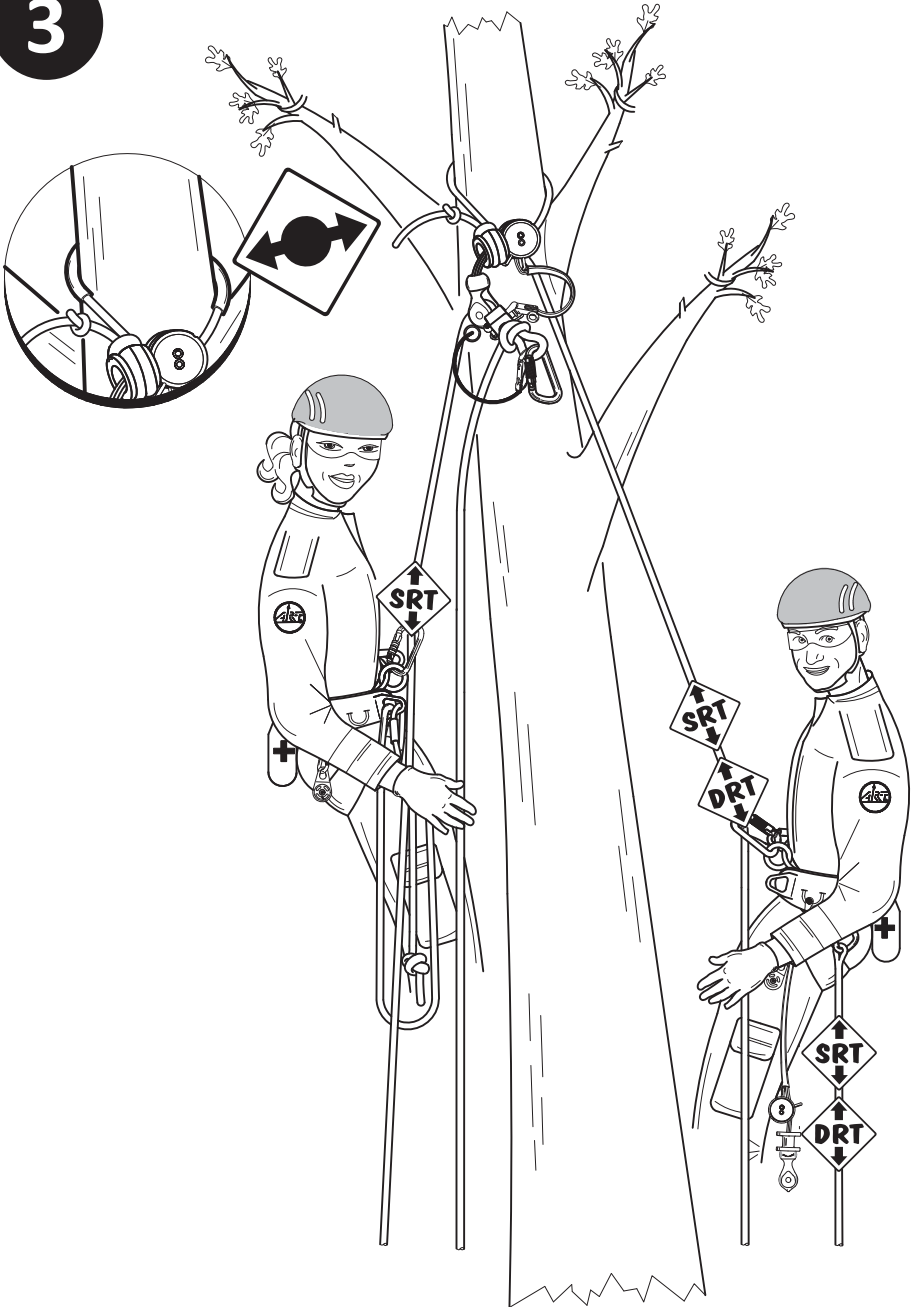

1

RopeGuide TwinLine:

4

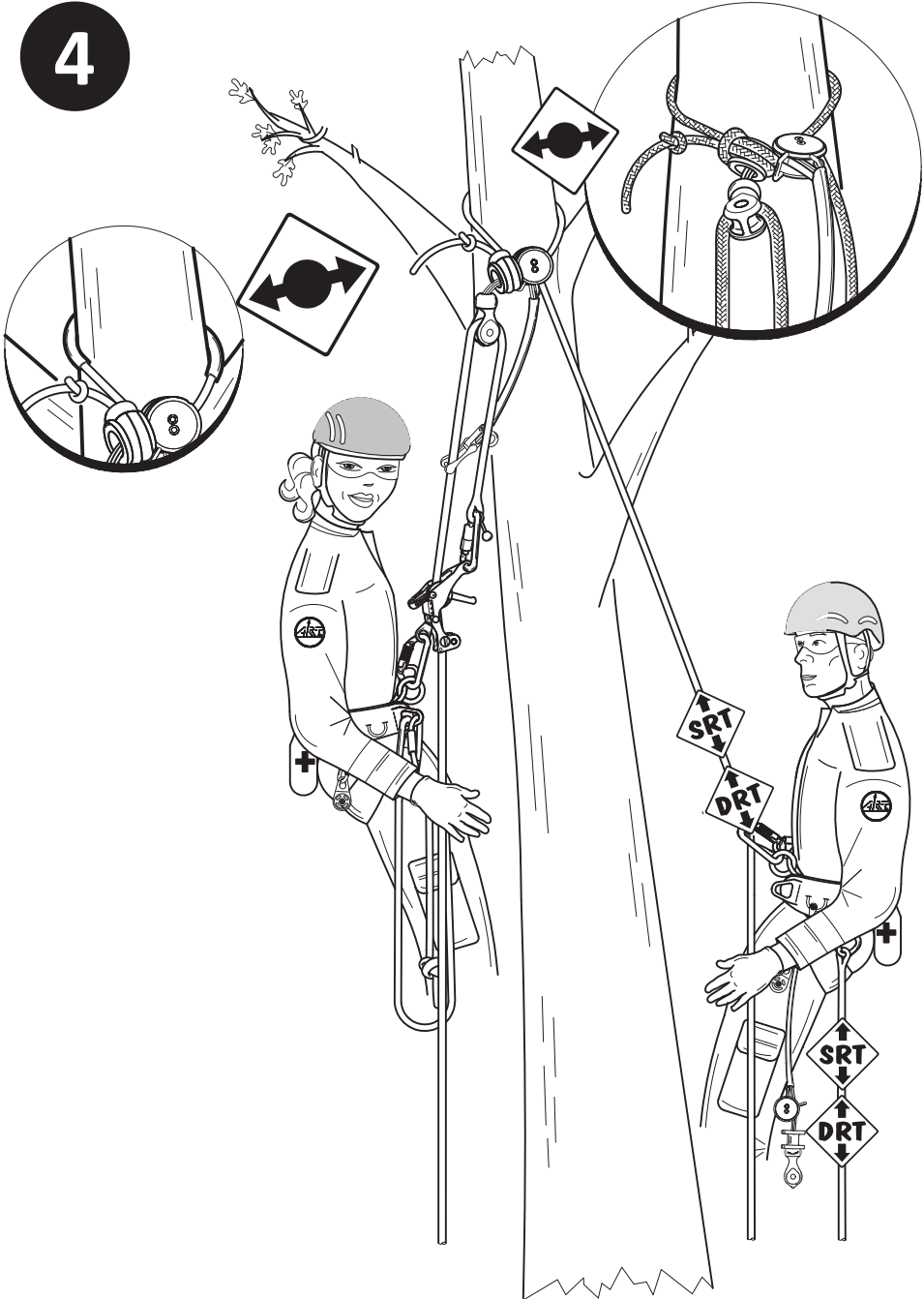

RopeGuide TwinLine:

1

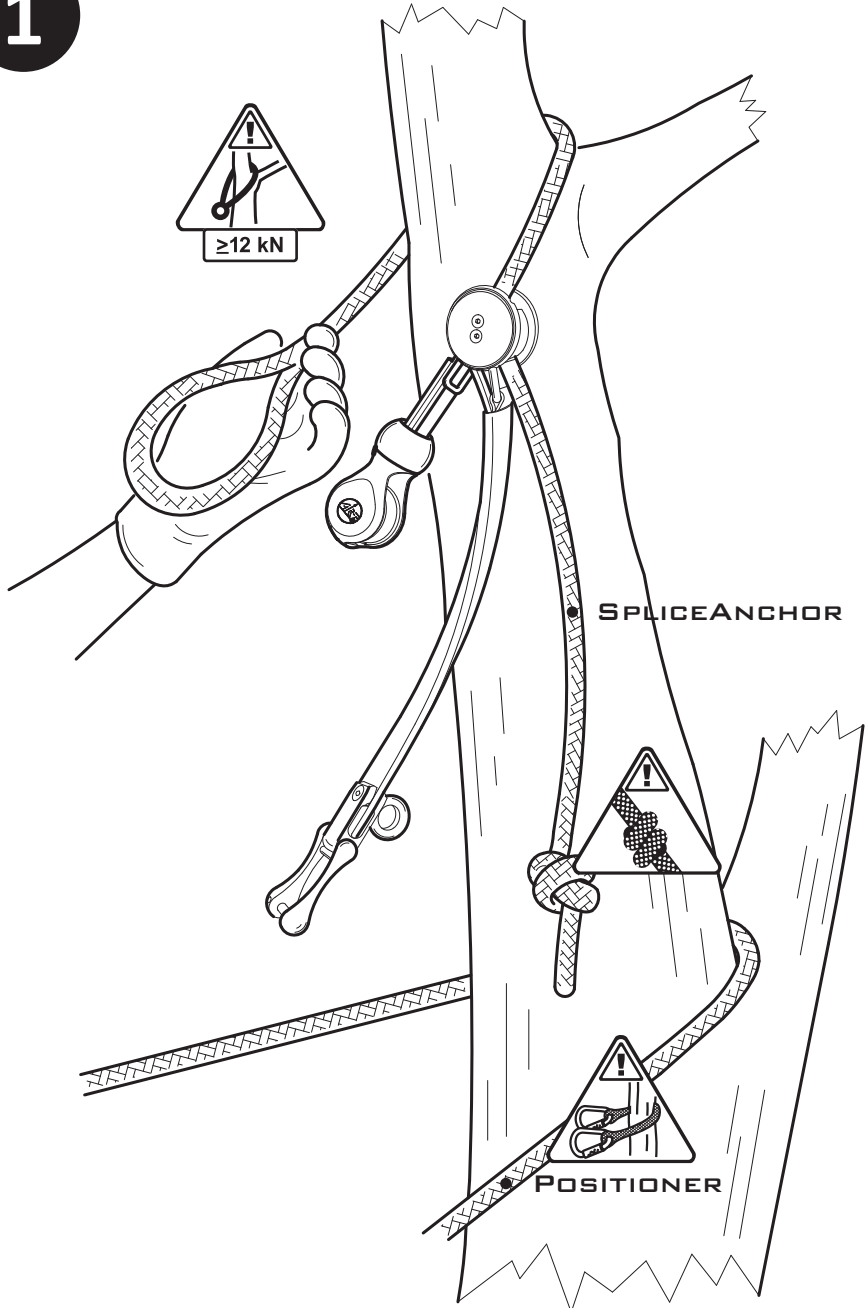

J

RopeGuide TwinLine:

2

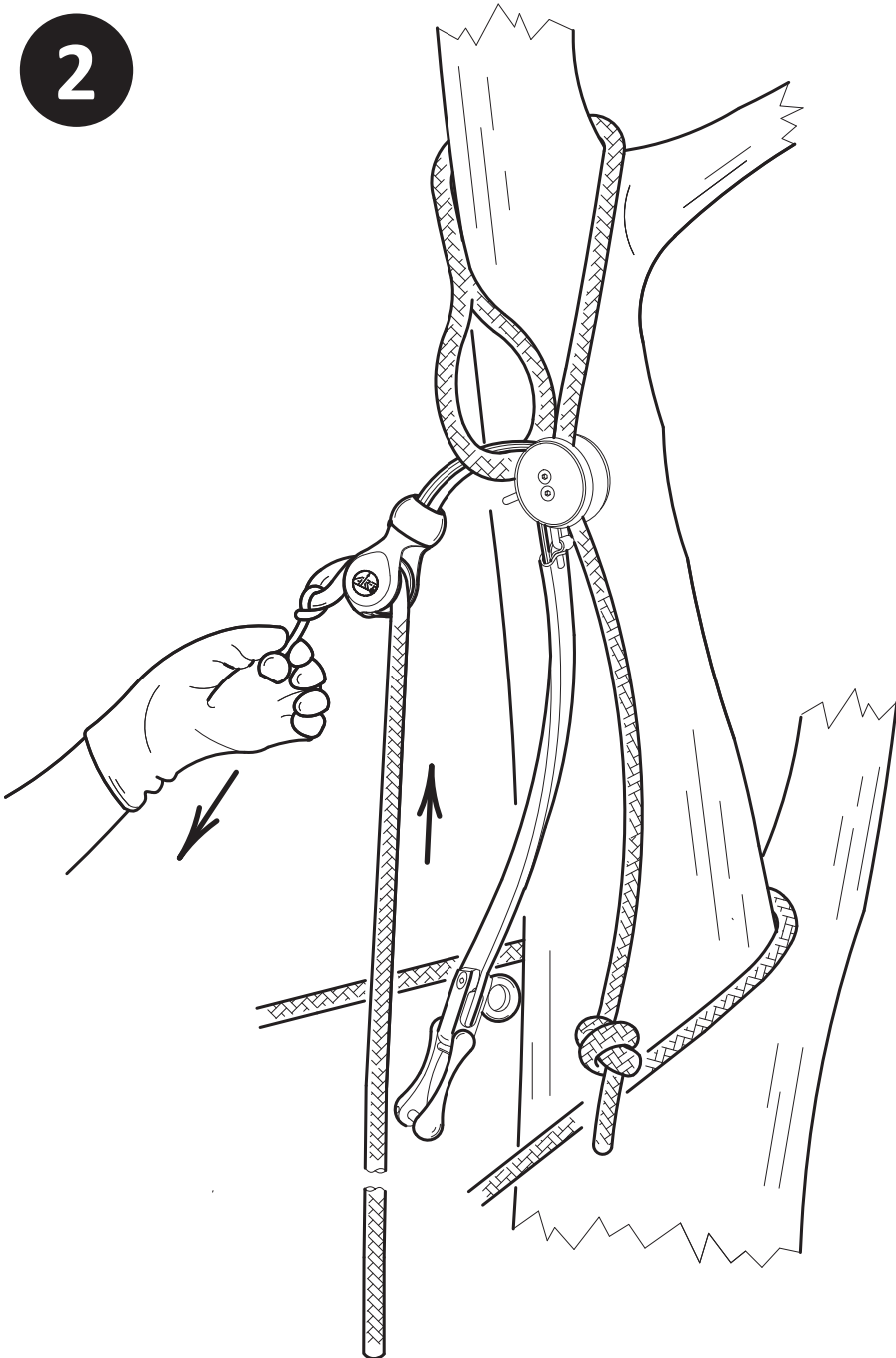

RopeGuide TwinLine:

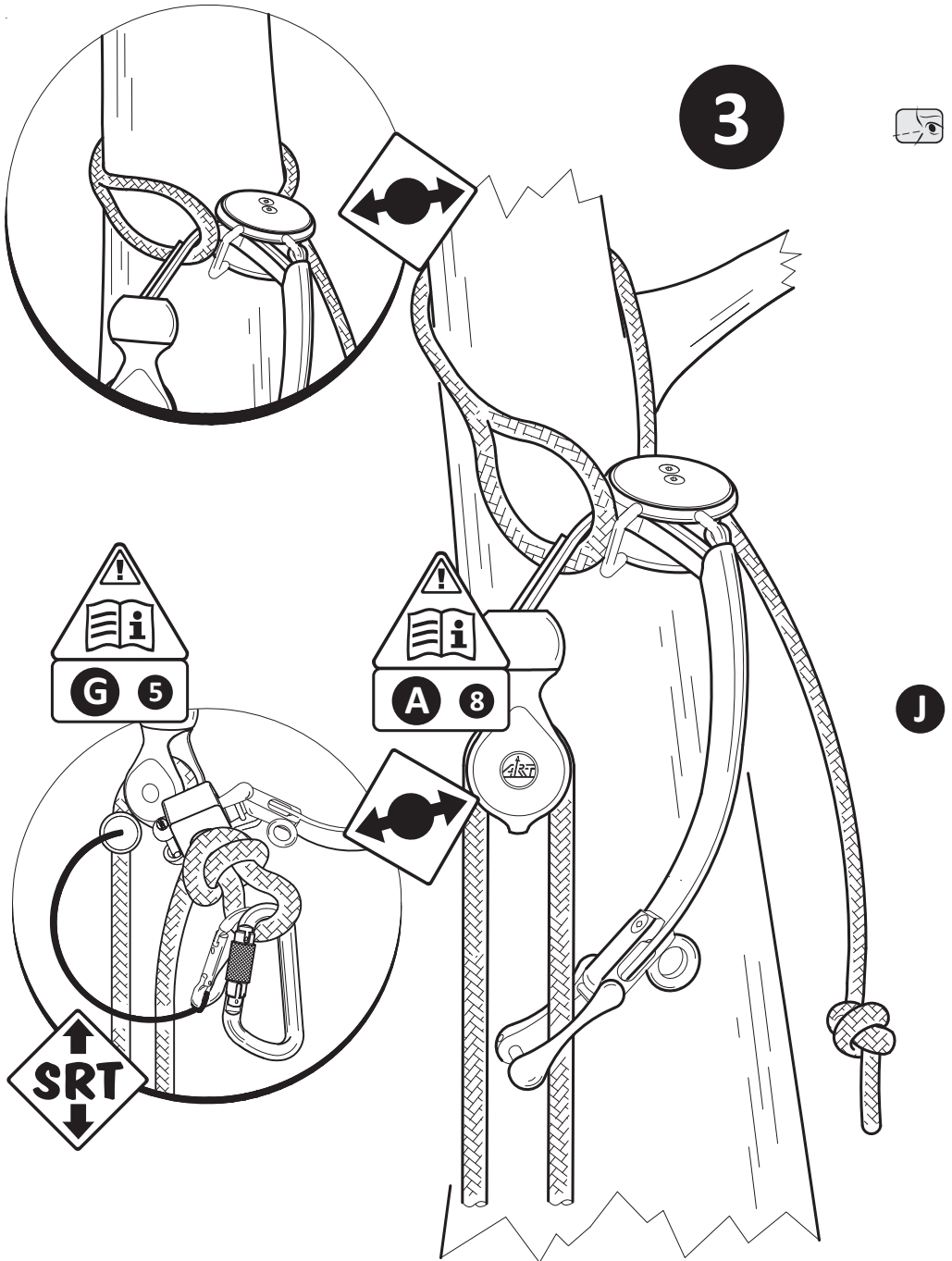



For The **ART** Of Treeclimbing

RopeGuide TwinLine:

1

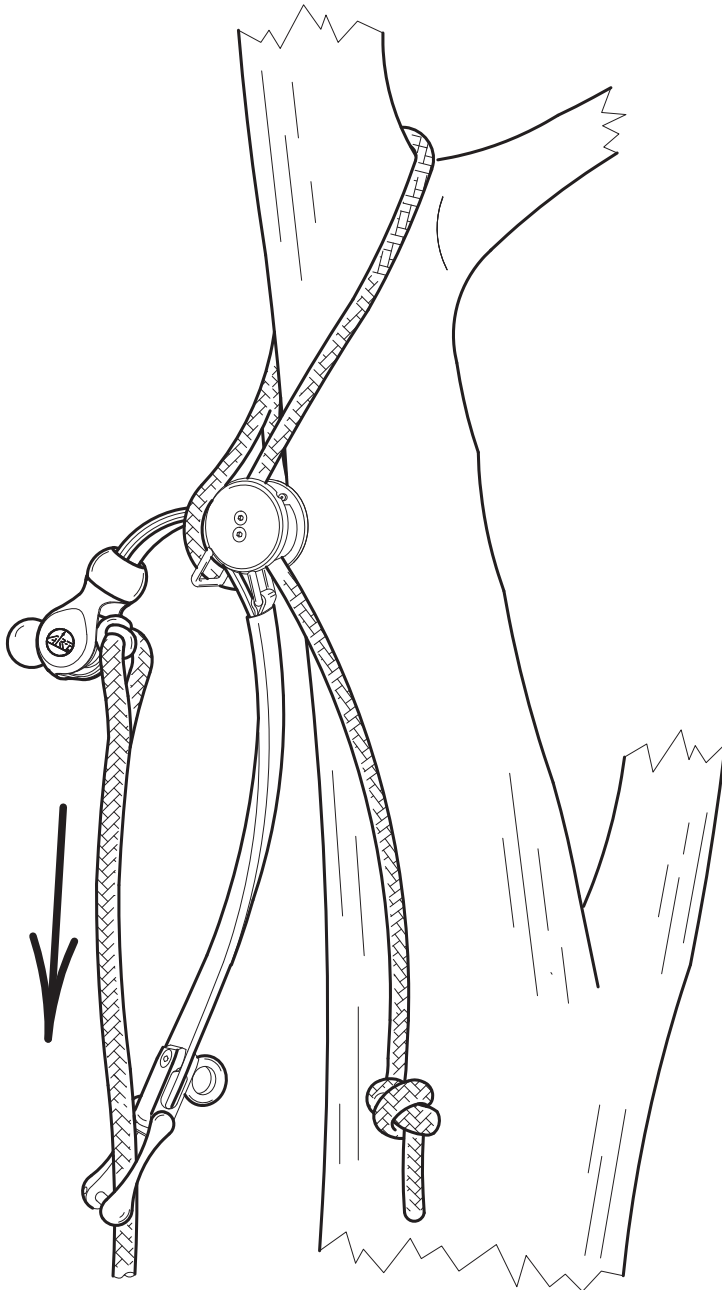

K

RopeGuide TwinLine:

2

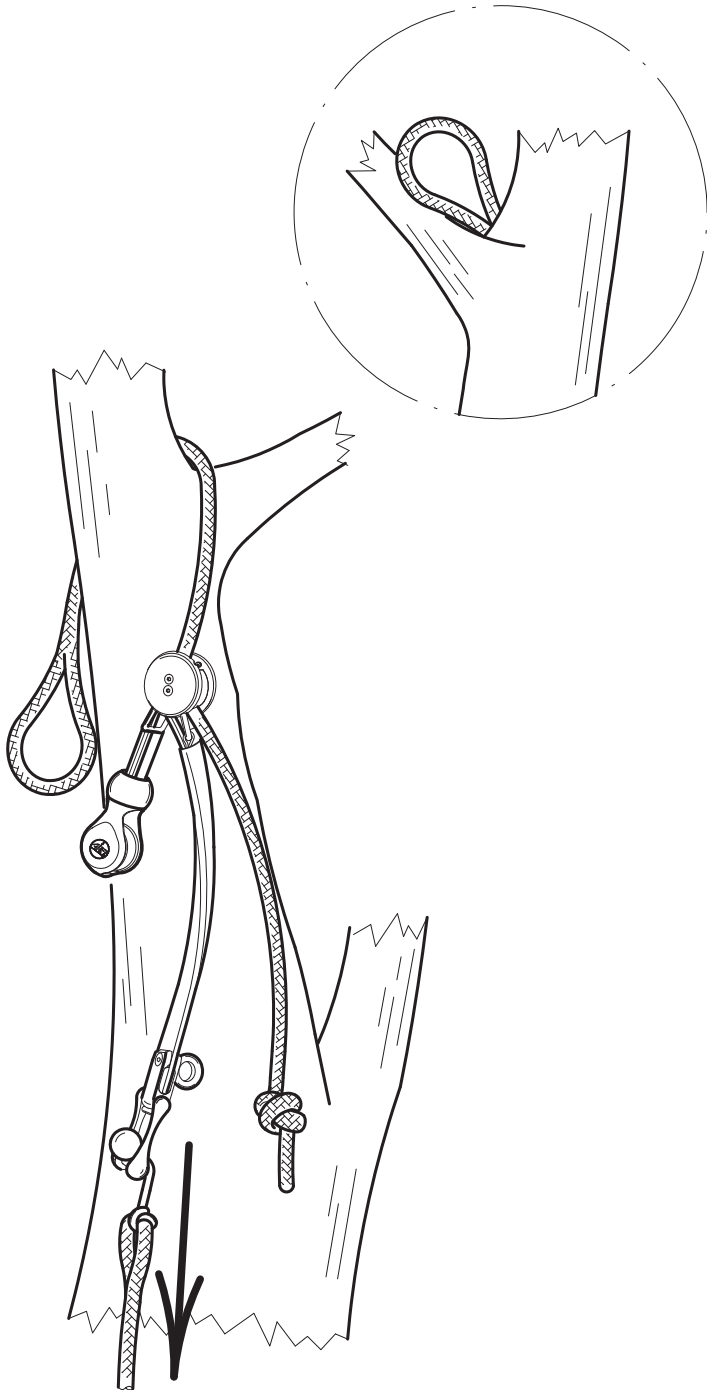

RopeGuide TwinLine:

1

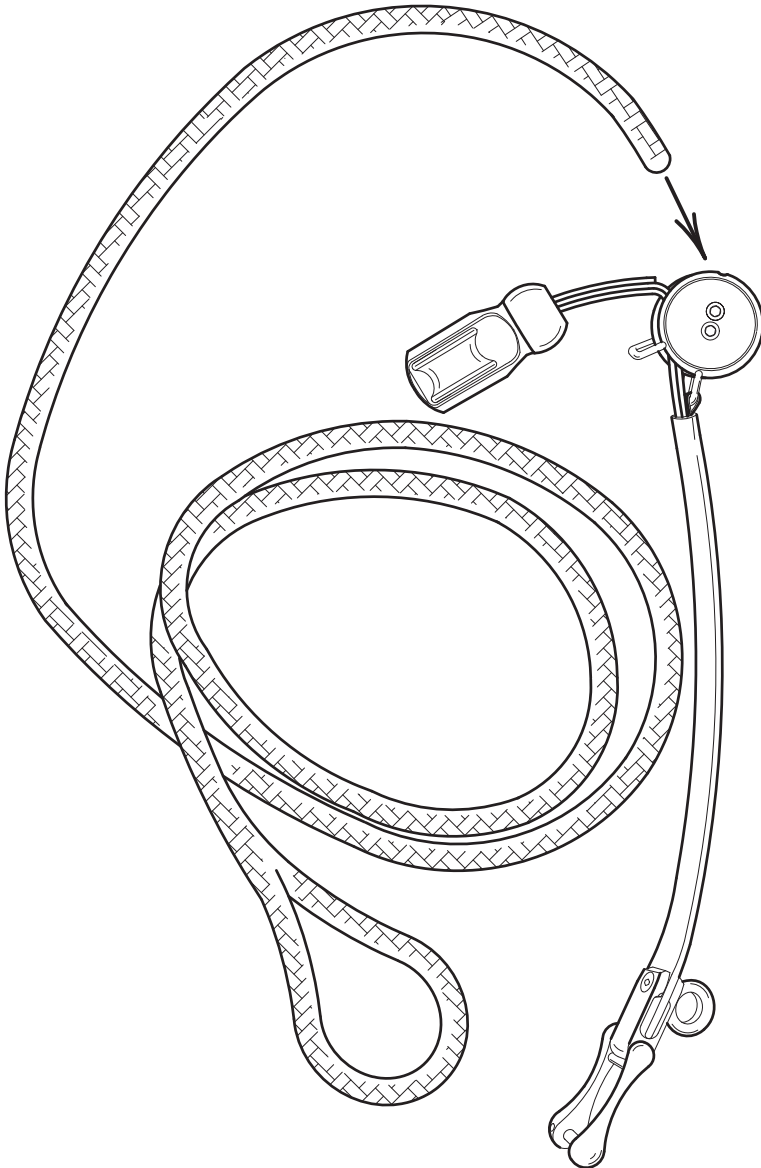

L

RopeGuide TwinLine:

2

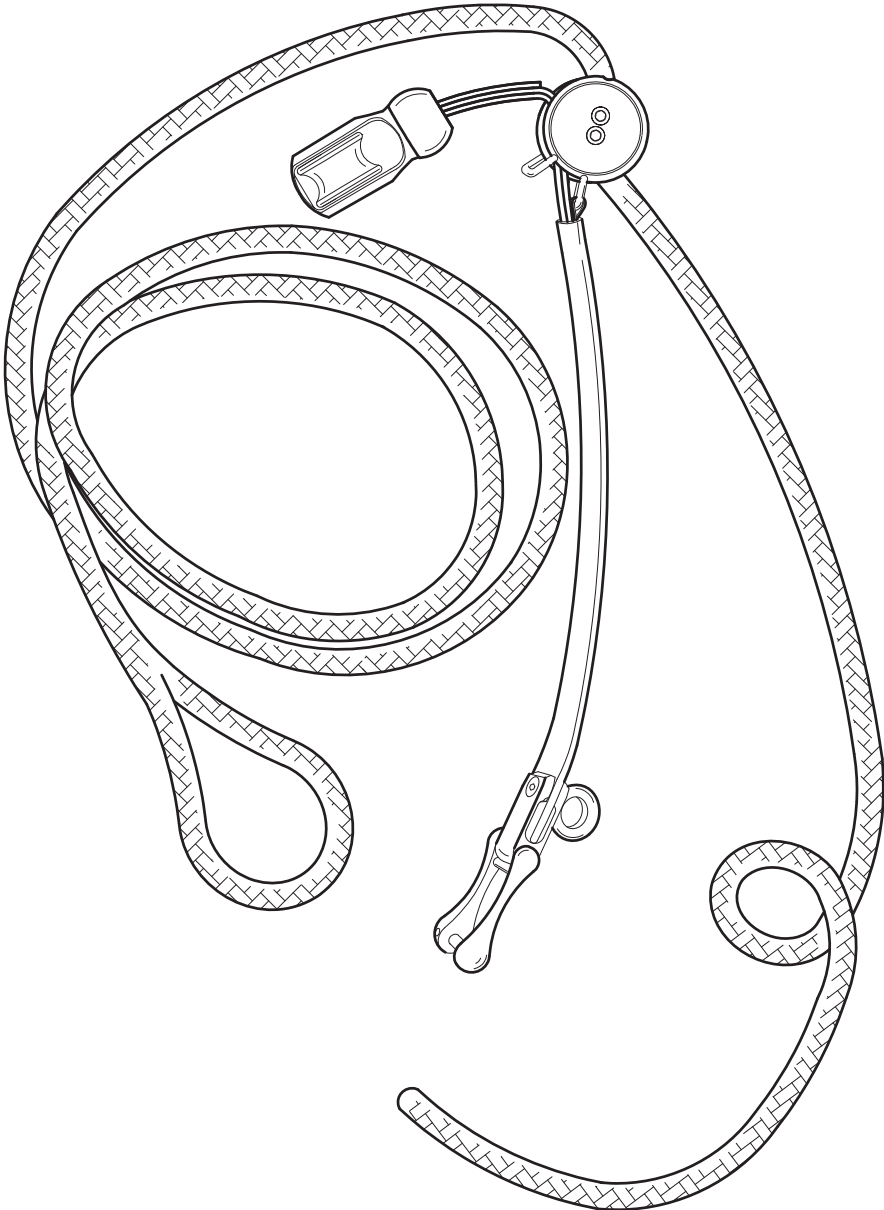

RopeGuide TwinLine:

3

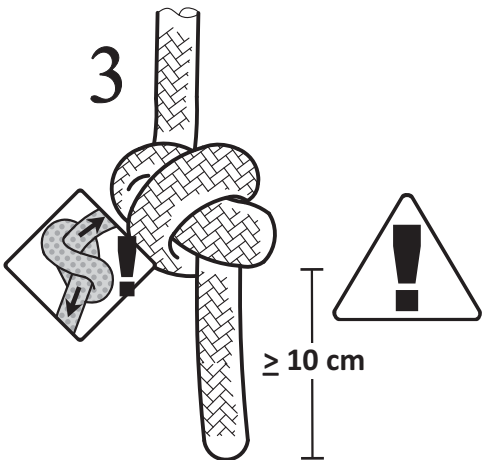
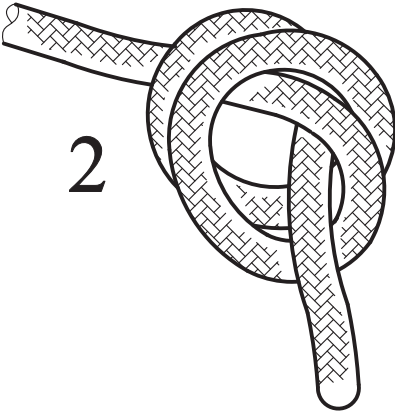
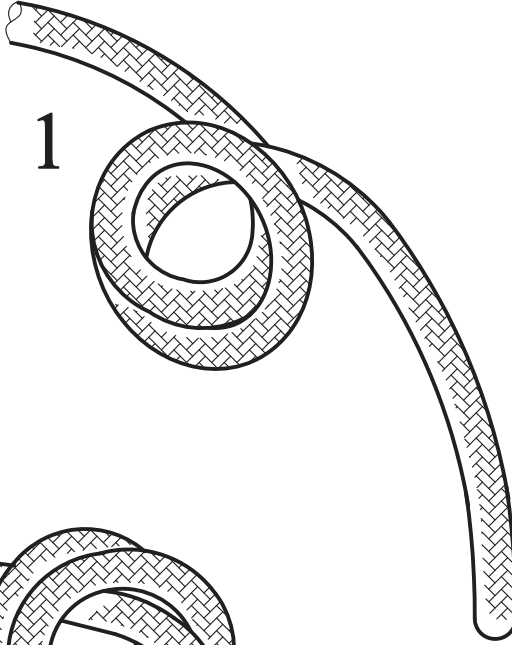

L



For The **ART** Of Treeclimbing

RopeGuide TwinLine:

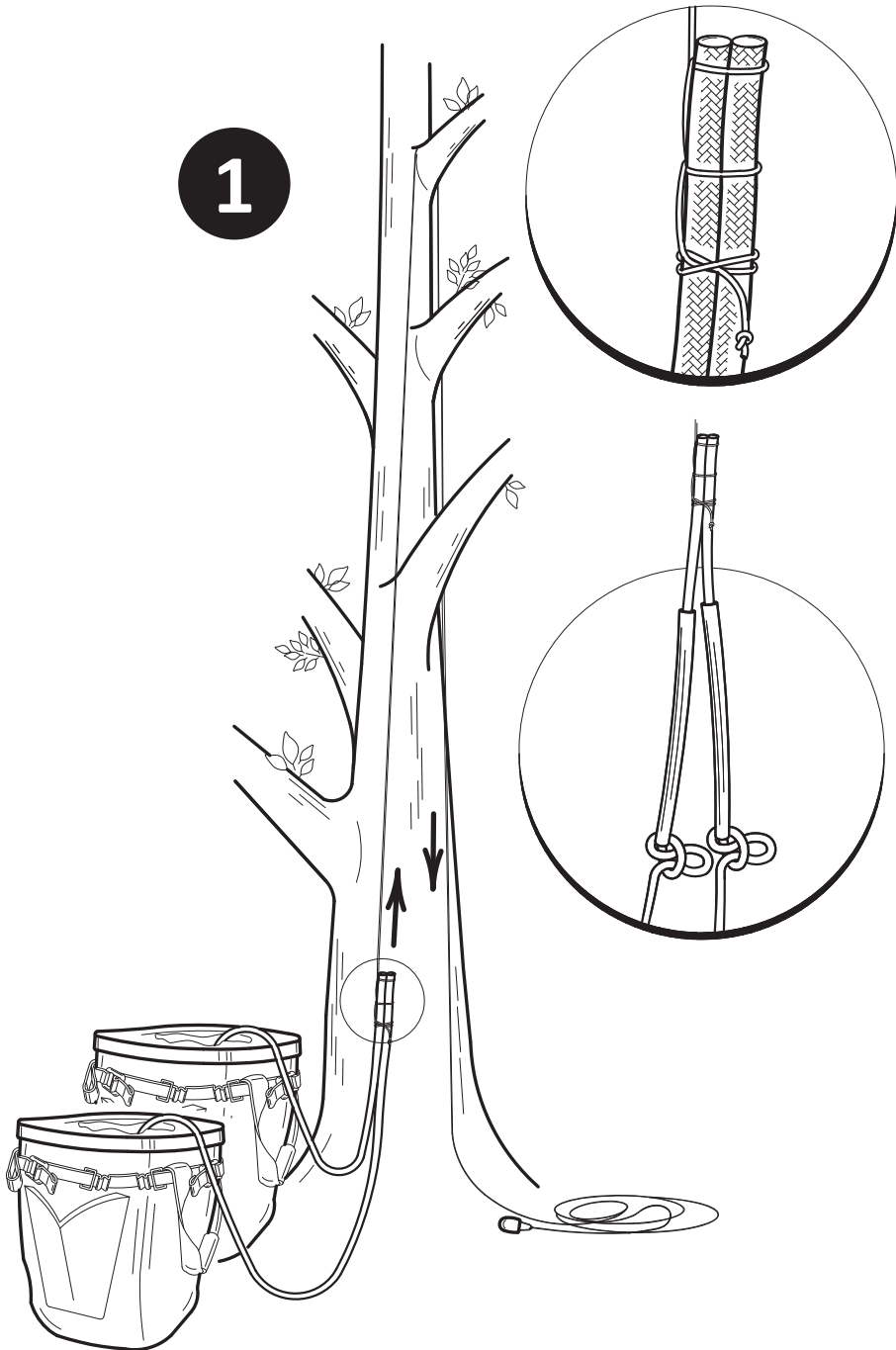

M

RopeGuide TwinLine:

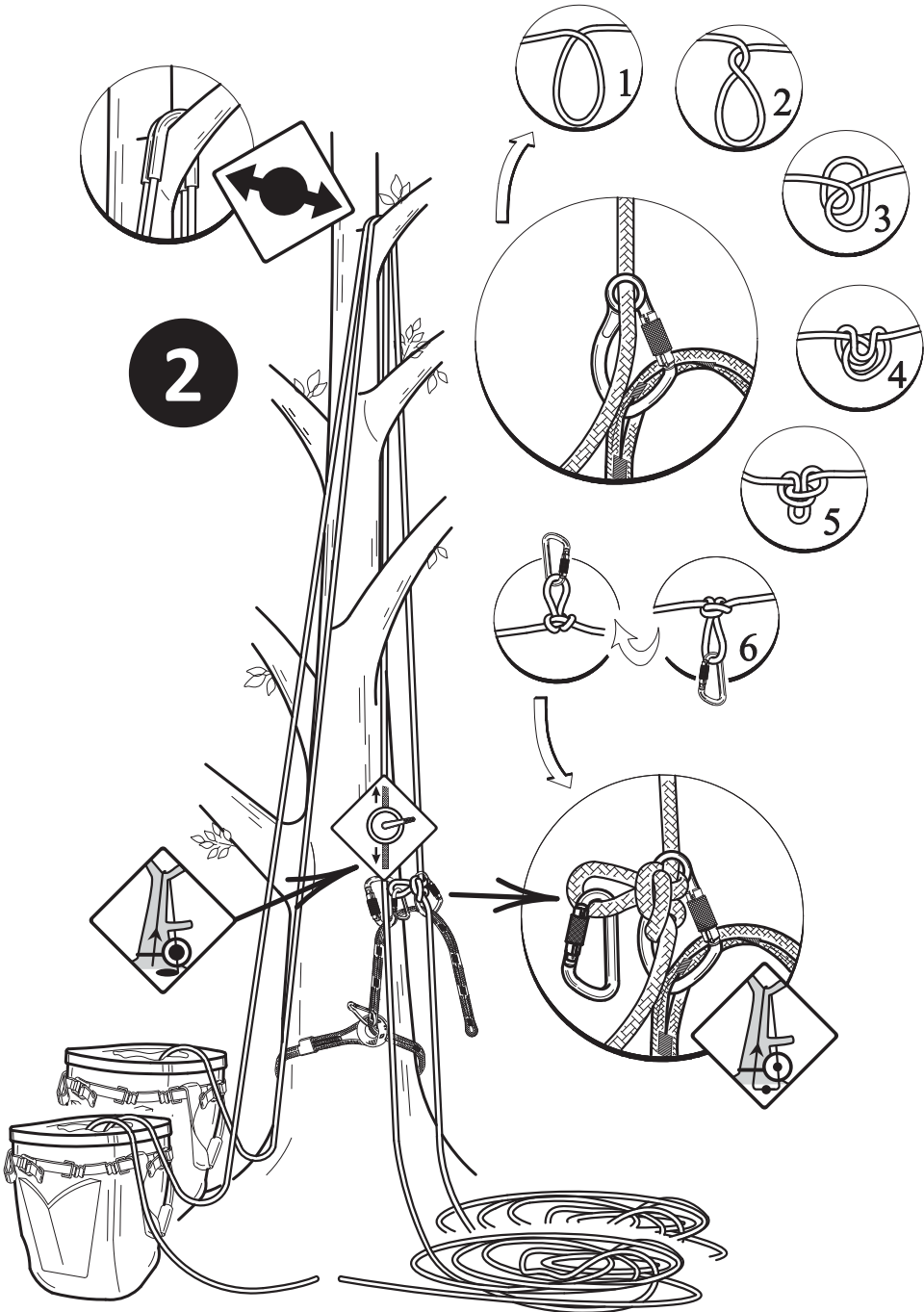

RopeGuide TwinLine:



RopeGuide TwinLine:

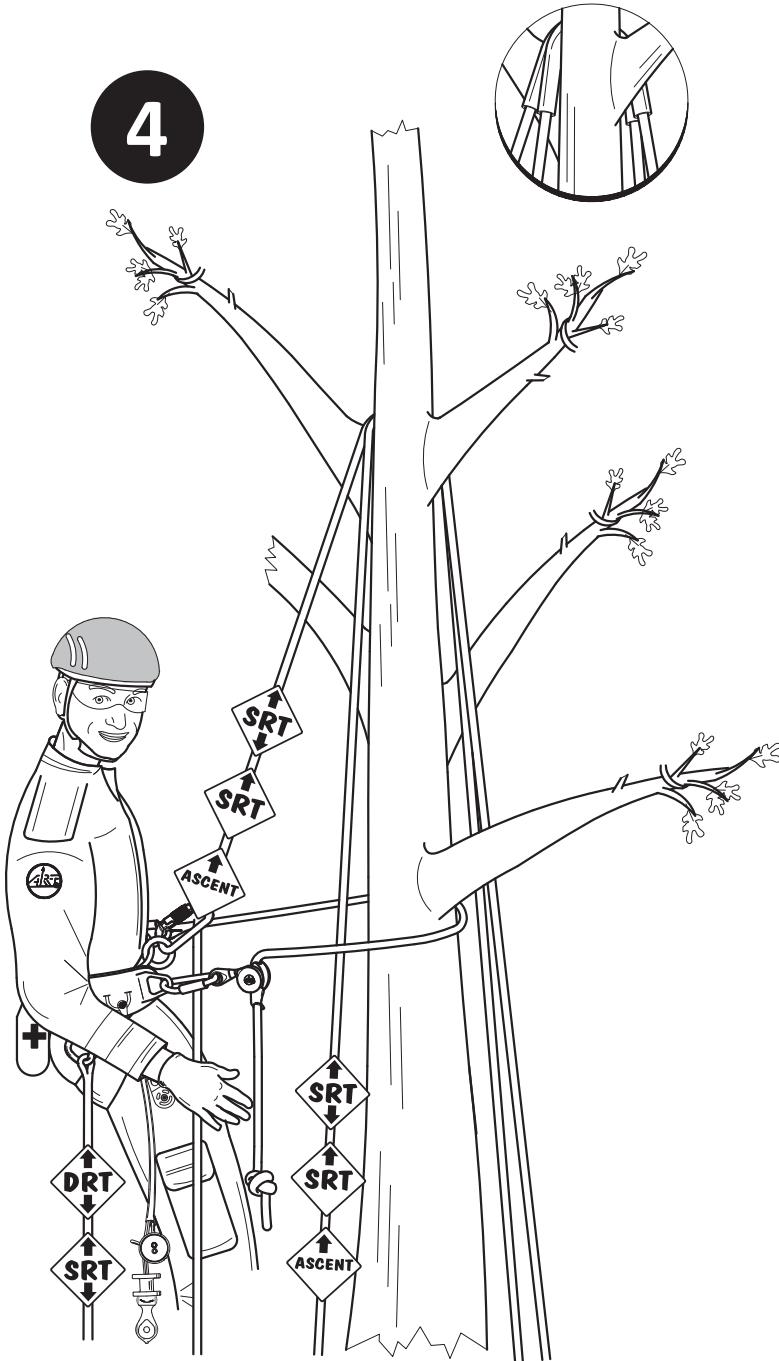

RopeGuide TwinLine:

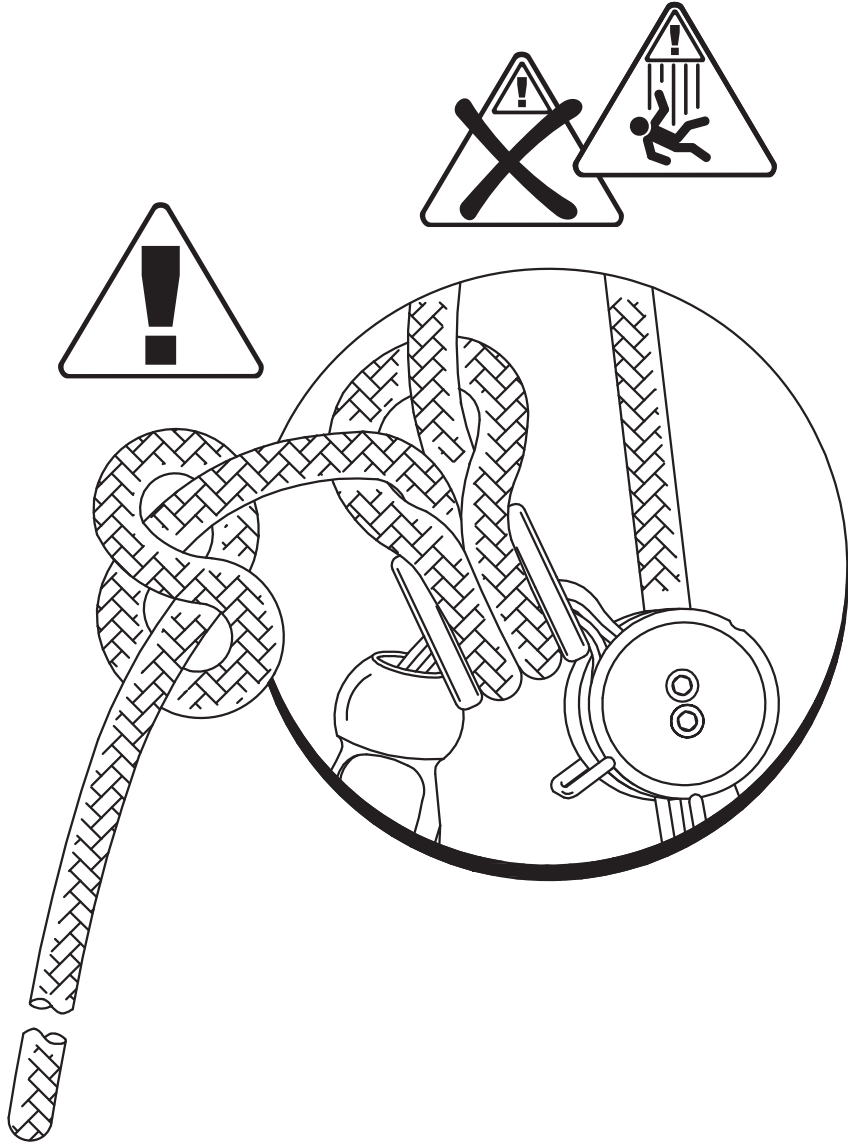

RopeGuide TwinLine:

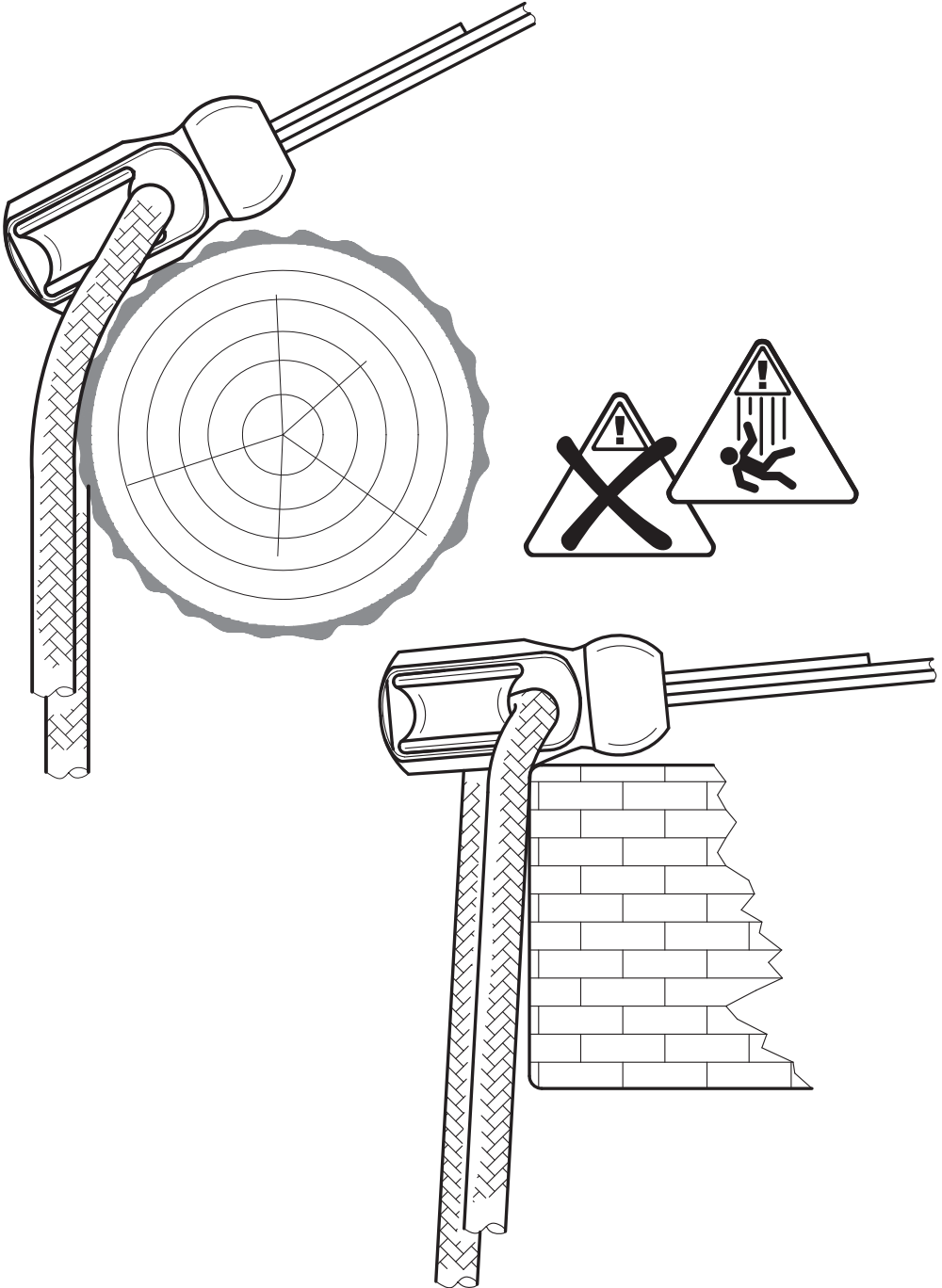

RopeGuide TwinLine:

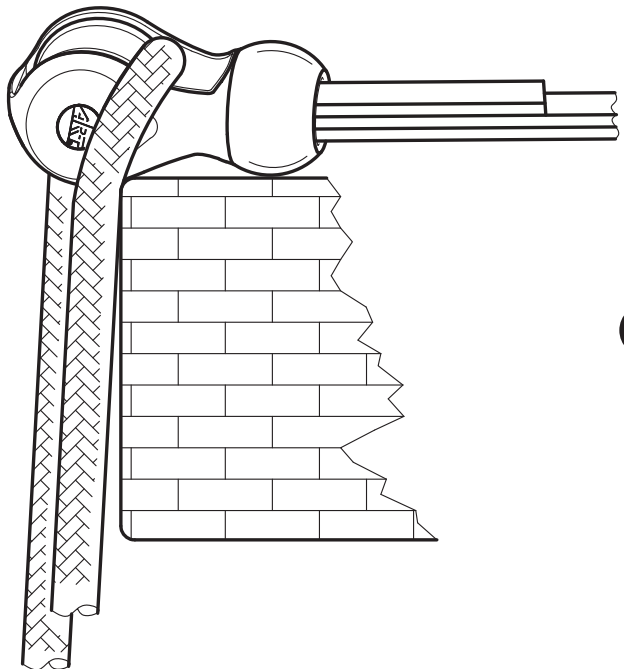
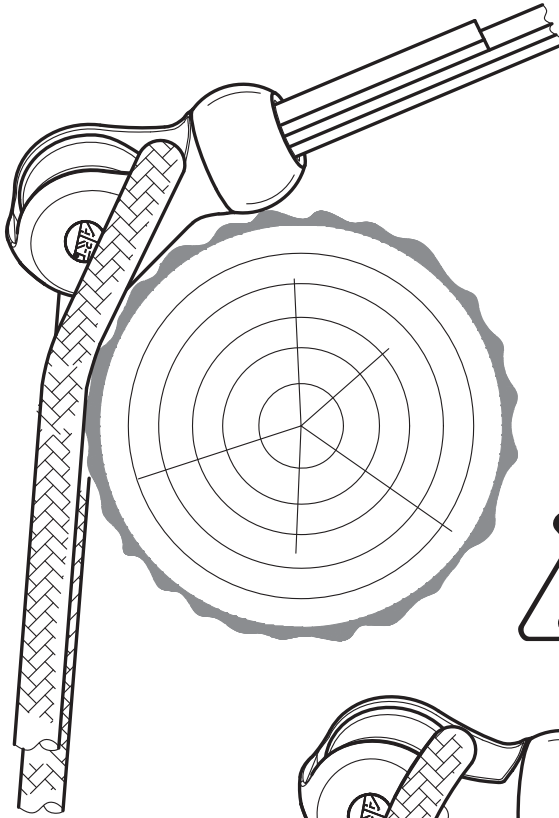

RopeGuide TwinLine:

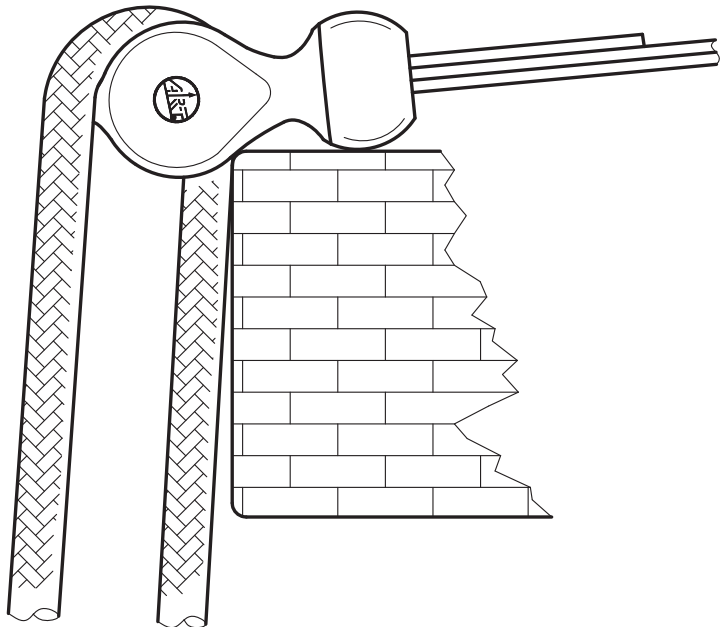
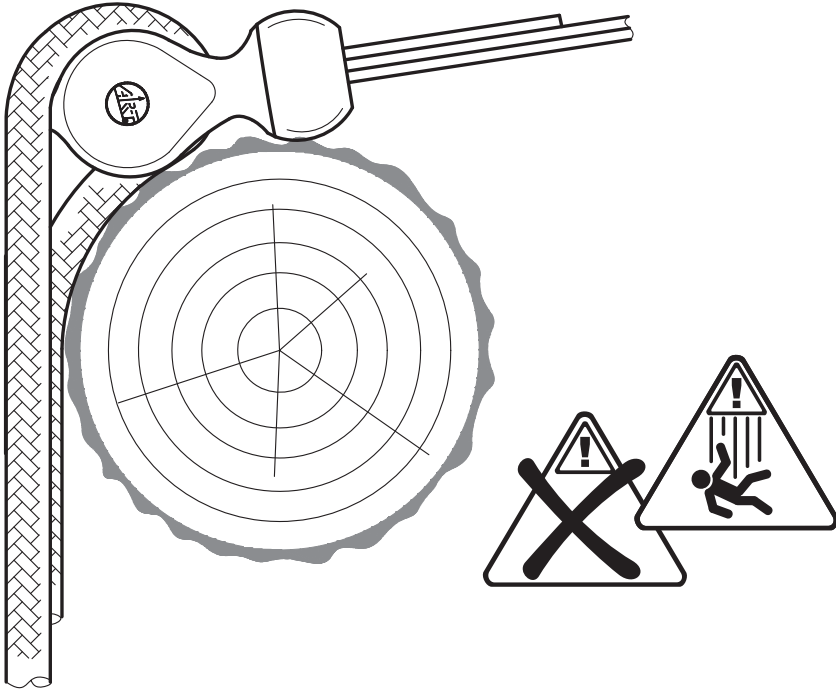

Notizen / Notes / Notices / Notas / Appunti

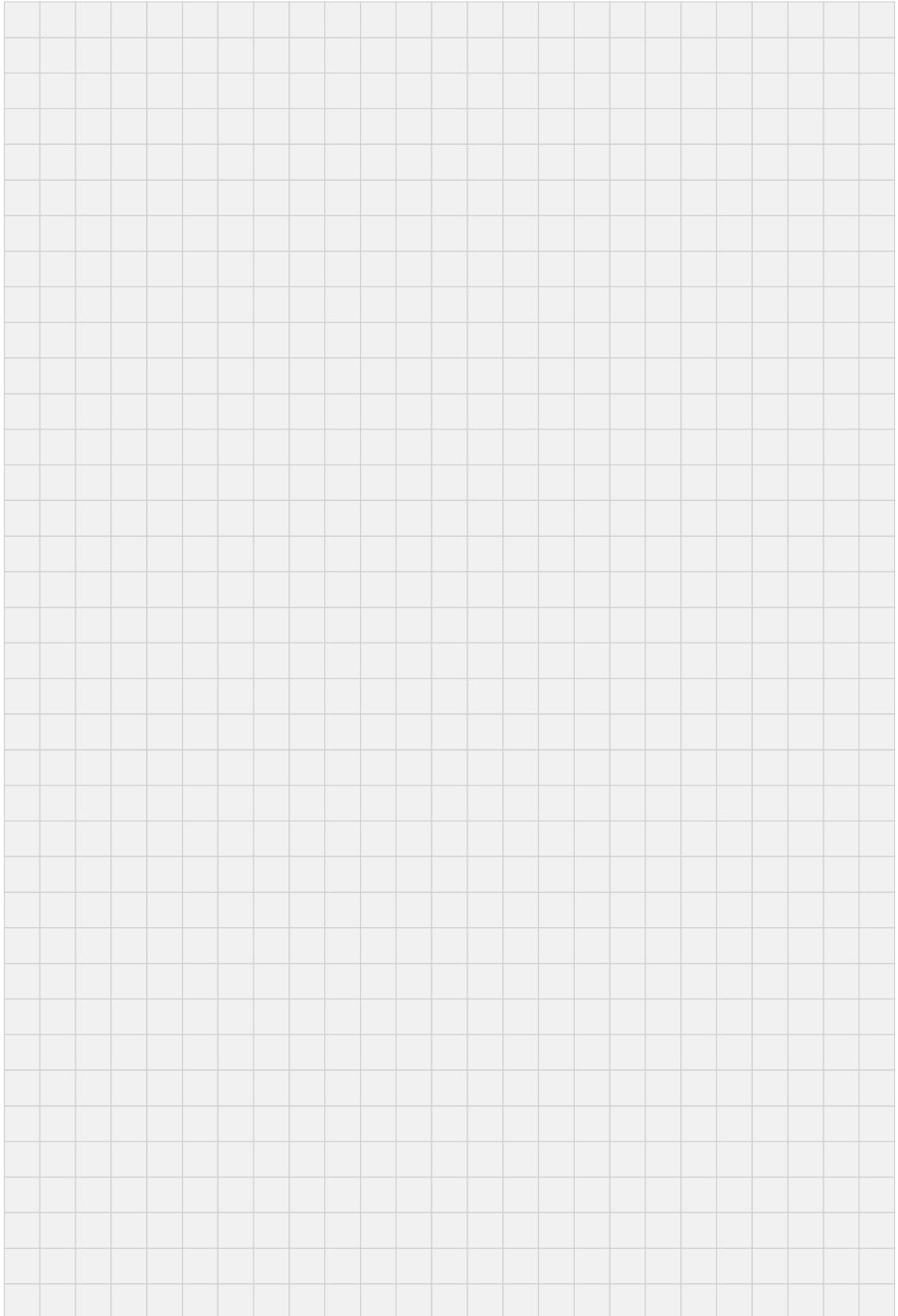

**Kontrollkarte / Inspection card / Carte de contrôle
Ficha de control / Scheda di controllo**

Kaufdatum:
Purchase date:
Date d'achat:
Fecha de la compra:
Data di acquisto:

Datum des ersten Einsatzes:
Date of first use:
Date de la première utilisation:
Fecha del primer empleo:
Data di primo impiego:

Name des Benutzers:
Name of the operator:
Nom de l'utilisateur:
Nombre del usuario:
Nome dell'utilizzatore:

Bemerkungen zum Einsatz / Remarks on use / Remarques concernant la première utilisation / Observaciones referentes al empleo / Osservazioni relative all'impiego

Hubert Kowalewski e.K.
In den Sennen 19
D-32369 Rahden-Wehe



Telefon +49 5771 608783
Telefax +49 5771 608782
www.climb-ART.com

Überprüfungen / Inspections / Contrôles / Comprobaciones / Verifiche

Datum	Bemerkungen	Unterschrift
Date	Notes	Signature
Date	Remarques	Signature
Fecha	Observaciones	Firma
Data	Osservazioni	Firma

Hubert Kowalewski e.K.
In den Sennen 19
D-32369 Rahden-Wehe



Telefon +49 5771 608783
Telefax +49 5771 608782
www.climb-ART.com

"Neue Ideen sind die Basis für Innovation und Fortschritt !"

**"New ideas form the basis
of innovation and progress !"**

**"nouvelles idées sont la base
de l'innovation et du progrès !"**

**"¡ Nuevas ideas forman la base
de innovación y progreso!"**

**"Le nuove idee costituiscono la base
di innovazione e progresso!"**

Hubert Kowalewski

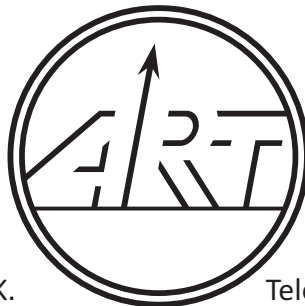

Hubert Kowalewski e.K.
In den Sennen 19
D-32369 Rahden-Wehe

Telefon +49 5771 608783
Telefax +49 5771 608782
info@climb-art.de

www.climb-ART.com