

INSTRUCTIONS FOR USE AND MAINTENANCE

MICRO-CYLINDRE LOWERING DEVICE

REF.

FTC/MCC-T

SERIAL NO.

JULY 2017 VERSION (TRANSLATED)

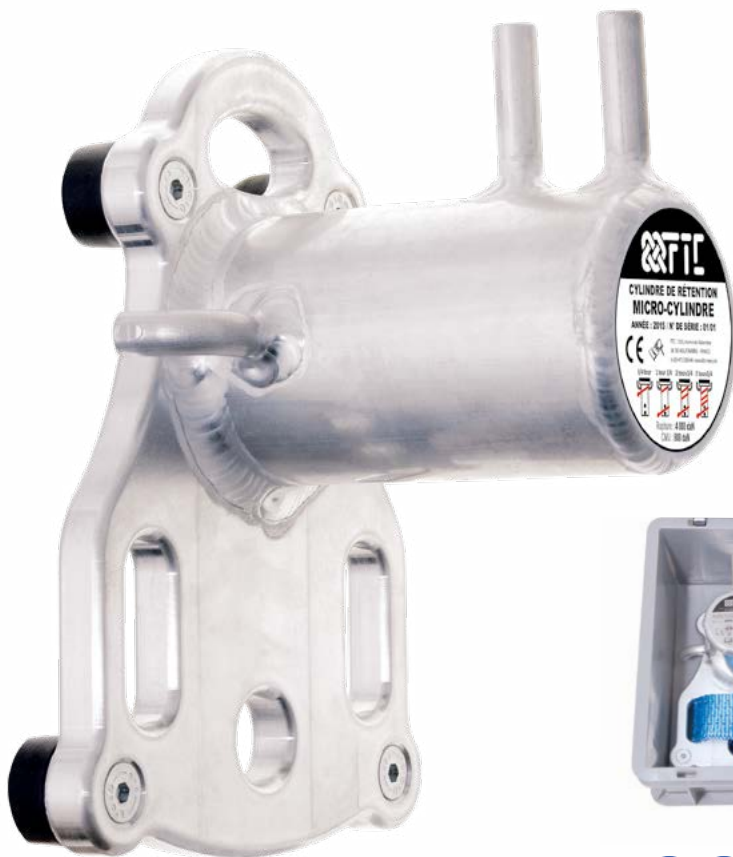

1355, chemin de Malombre • Z.I. Les Plaines
26780 MALATAVERNE • FRANCE • (+33) 475 528 640
contact@ftc-tree.com • www.ftc-tree.com

FTC
PLAY WITH GRAVITY

1 TECHNICAL DATA

Weight	1,7 kg
Total weight with 9 m strap and transport box	4,7 kg
MBS and cylinder distortion	4,000 daN
Working Load Limit (WLL)	800 daN

2 EQUIPMENT DESCRIPTION

2.1 • FIXING

- Base plate with rubber protection pads
- Steel ratchet with 50 mm polyester strap - 9 m long, MBS 7500 daN
- Stainless steel tilting pin - Ø 12 mm, 80 mm long

2.2 • LOWERING DEVICE

- Aluminium friction cylinder - Ø 75 mm, 5 mm thick
- Rigging rope fairleads: 1 on right and 1 on left, curved and symmetric for entering rope, 2 vertical for exiting rope

2.3 • COMFORT ACCESSORY

- A half-oval hole for an easier setting up (with the CROCH'TY), or to fix a carabiner for reeving

2.4 • MARKINGS ON LABEL (see page 8)



3 USE



ONLY FOR TREE CARE WORK.

The MICRO-CYLINDRE is a friction device for rigging ropes used during tree care. It is used when tree felling to hold and lower cut branches or logs. It attaches to the base of the tree to be felled, or to any tree able to resist the stress and shock produced during moving of loads.

This device must be used:

- On a tree (attached) and with equipment (ropes, carabiners, mechanical adjusters, etc.) having compatible size and resistance properties to the rope loads,
- By trained and/or competent people,
- In respect of the manufacturer's and/or seller's recommendations,
- Only after having read and understood these instructions.



UNDER NO CIRCUMSTANCES SHOULD THIS EQUIPMENT BE USED FOR BELAYING.

4 TRANSPORT / CARE / STORAGE

4.1 • TRANSPORT

Shocks and other poor treatment can weaken the material and cause serious, and even invisible, damage. During transport and use, take the necessary precautions. Do not put the piece of equipment in contact with abrasive, acidic or corrosive materials that can damage it and/or reduce its technical performance. Ropes soiled by dirt, sand, oil, etc., can cause a higher risk of wear to the bollard and lower its performance.

4.2 • CLEANING / CARE

- Rubber and aluminium parts: Clean water less than 40°C, clean cloth, mild detergent.
- Fixing system:
 - Ratchet: Clean water, clean cloth, mild detergent.
 - Strap: Clean water less than 40°C, mild detergent.
- Markings: Clean water, clean cloth. (Replace if worn, see chapter 7).
- Regularly check that the rubber pads are still fastened with a 5 mm Allen key.

4.3 • STORAGE

In a dry place, free from exposure to weather; shocks; heat sources more than 40°C; and abrasive, acidic or corrosive materials capable of damaging it and/or reducing its technical performance.

4.4 • REPAIRS



**REPAIRS BY ANYONE OTHER THAN FTC ARE PROHIBITED.
ONLY WEAR PARTS (ratchet and straps, see chapter 2.1) CAN BE REPLACED.
ONLY GENUINE MANUFACTURER PARTS GUARANTEE PROPER FUNCTIONING OF THE DEVICE.**

5 RECOMMENDATIONS BEFORE USE

5.1 • READ THE INSTRUCTIONS

- Read and understand the instructions.
- For any questions or additional information, contact the vendor.



5.2 • INSPECT BEFORE AND DURING USE

- The competence of the users.
- Legibility of marking symbols (see chapter 7).
- Good condition of fairleads (no distortion).
- Correct positioning of the rigging rope (entry angle on the cylinder).
- MBS composition (cylinder rope, pulley, sling pulley, anchoring point pulley).
- Solidness of the chosen support.
- Placement and tightening of the base plate.
- Condition of the strap, ratchet and its attachment.
- General condition of the rope friction surfaces.
- Compatibility and resistance of the rigging ropes.
- Respect of the instructions and recommendations of use.



**NEVER USE IF ANY ONE
OF THESE FACTORS IS NOT
RESPECTED.**

6 INSTRUCTIONS FOR USE

6.1 • ATTACHING EQUIPMENT

It attaches to the base of the tree to be felled, or to any tree able to resist the stress and shock produced during moving of loads. To optimise tightening, the strap's longitudinal axis must be at a 90° angle to the vertical axis of the device's base plate.

During use, regularly check correct positioning, tightness and condition of the strap, as well as the condition of the tree serving as support. Warning: Inflicted or bleeding trees having surface defects or irregularities reduce the device's grip.

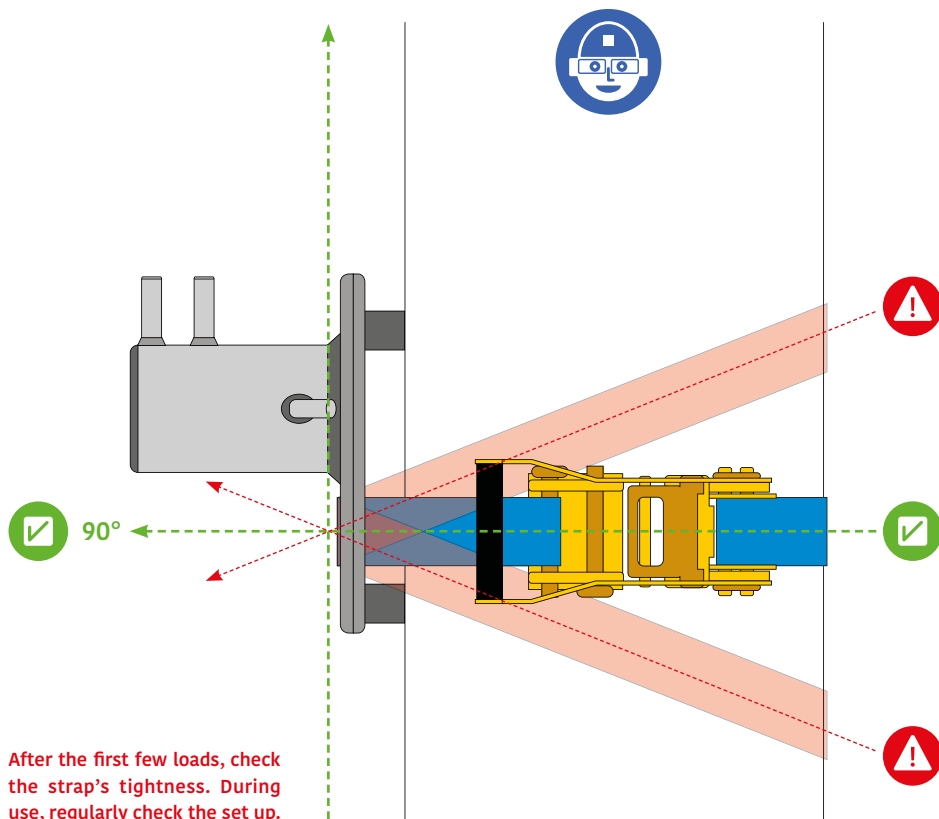

6.2 • USE OF THE CYLINDER

The cylinder's purpose is to provide restraint to felling loads. The braking strength depends on the rope type (diameter, design, etc.) and the number of wraps around the cylinder.

Only ropes used specifically for rigging, by virtue of their construction, guarantee correct operation of the device. Rope diameters that can be used are between a minimum of 10 mm and a maximum of 12 mm.



6.3 • APPROACH OF THE RIGGING ROPE TO THE CYLINDER

The rope's entry on the cylinder must respect two angles in order to ensure grip of the base plate to the trunk and to prevent it from falling off (see illustration).

6.4 • CORRECTING ROPE ENTRY

In order to respect these two angles, the rigging rope entry can be corrected (see illustrations below).

TO ENSURE A CORRECT POSITIONING OF THE ROPE, YOU CAN USE A REDIRECT
(see illustrations below).

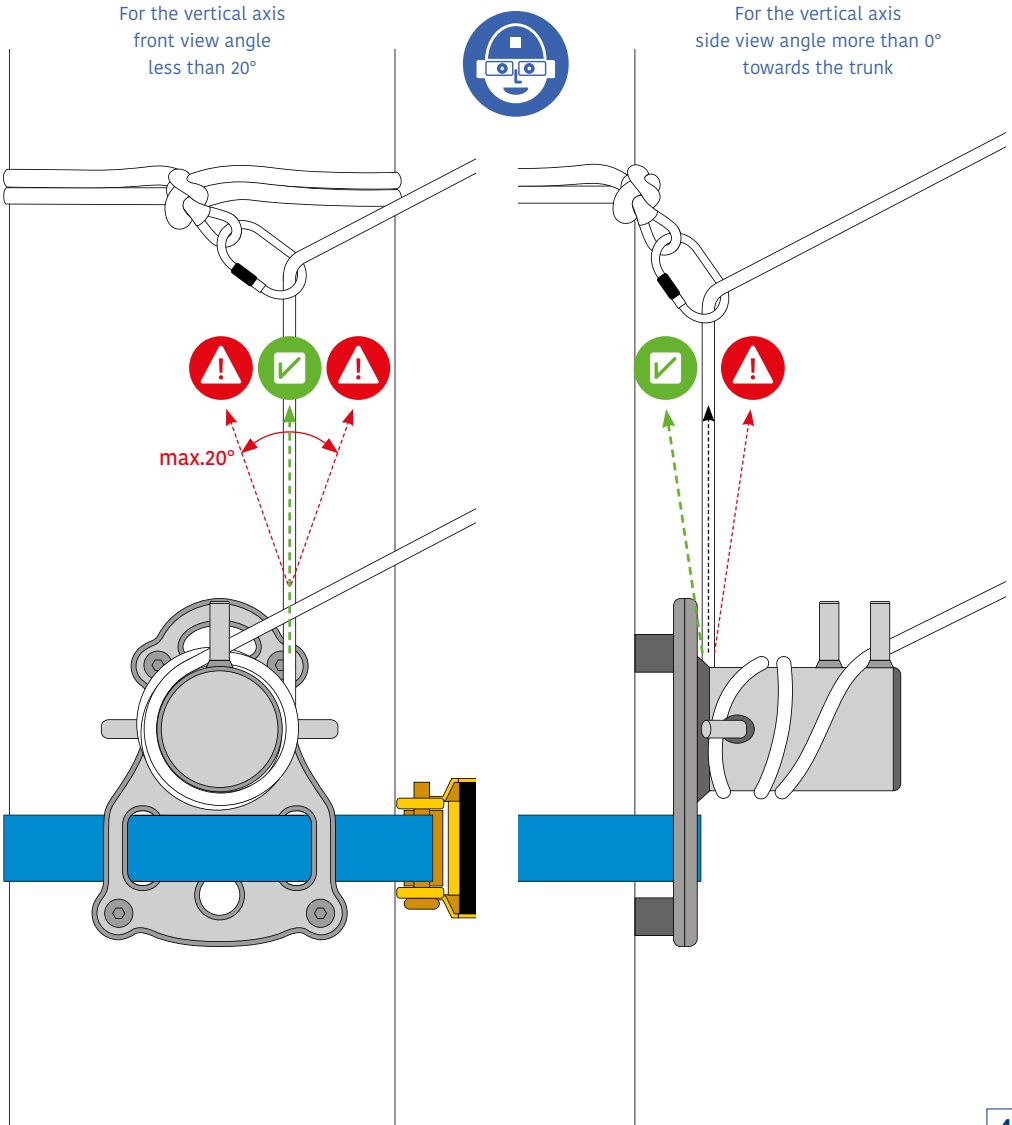

6.5 • POSITION OF THE RIGGING ROPE ON THE CYLINDER

The rope must strictly enter and exit through the rounded fairleads nearest to the plate (right or left). The last wrap must be separated from the others by passing between the two vertical fairleads in order to prevent overlapping of the rope when lowering the load. Overlapping of the rope can cause it to jam on the cylinder.

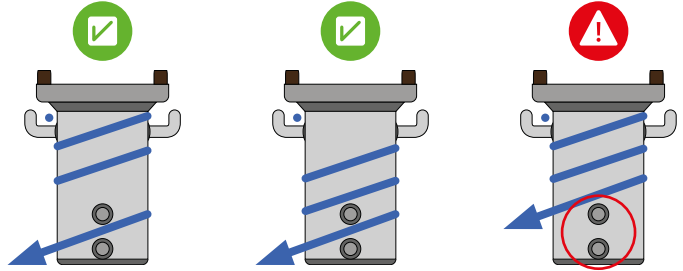

6.6 • RIGGING ROPE POSITIONS ON THE CYLINDER FOR BRAKING

For braking, the wrapping possibilities of the rope are: Minimum $\frac{3}{4}$ 4 wrap, then as many full additional wraps as needed—with no overlaps. The braking strength will vary according to the exerted force, rope diameter, design and general conditions of use (see illustration below for the braking strength solutions and the possible rope positions). The symmetry of the fairleads allows the rope to exit right or left without changing the number of wraps: for example, $2\frac{3}{4}$ wraps for a left or right exit.

A The rope is behind both curved fairleads

B The rope is behind one curved fairlead

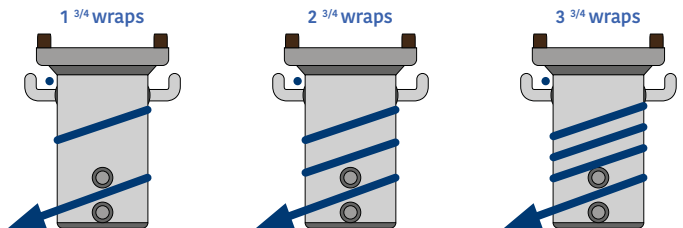
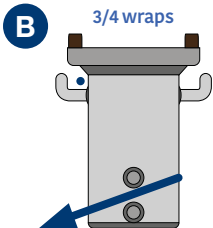
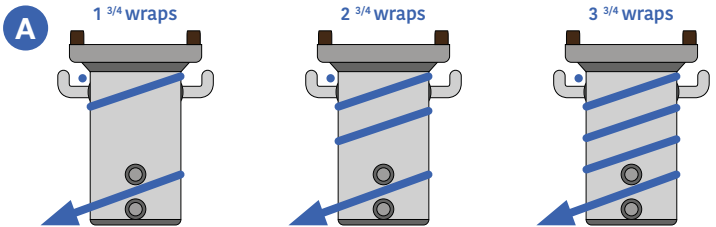

ONLY THE ROPE CONFIGURATIONS REPRESENTED IN THE FOLLOWING ILLUSTRATIONS ARE GUARANTEED.

ANY OTHER ASSEMBLY CANNOT BE CONSIDERED OPERATIONAL.

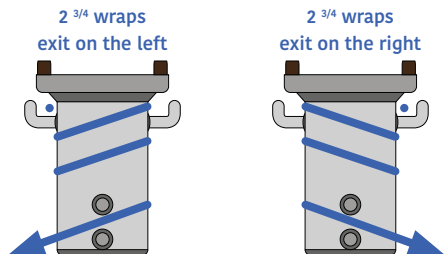

6.7 • LOCKING THE SYSTEM UNDER LOAD

To lock the system, you must make as many wraps as possible (the most wraps guarantee the possibility for easy, risk-free release) and secure by making figures of eight around the vertical fairleads with the slack going behind the first fairlead.

BRAKING STRENGTHS

As an example, the braking strengths measured with a \varnothing 12 new ANACONDA rope are:

3/4 wrap	75 daN
2 3/4 wraps	250 daN
3 3/4 wraps	800 daN

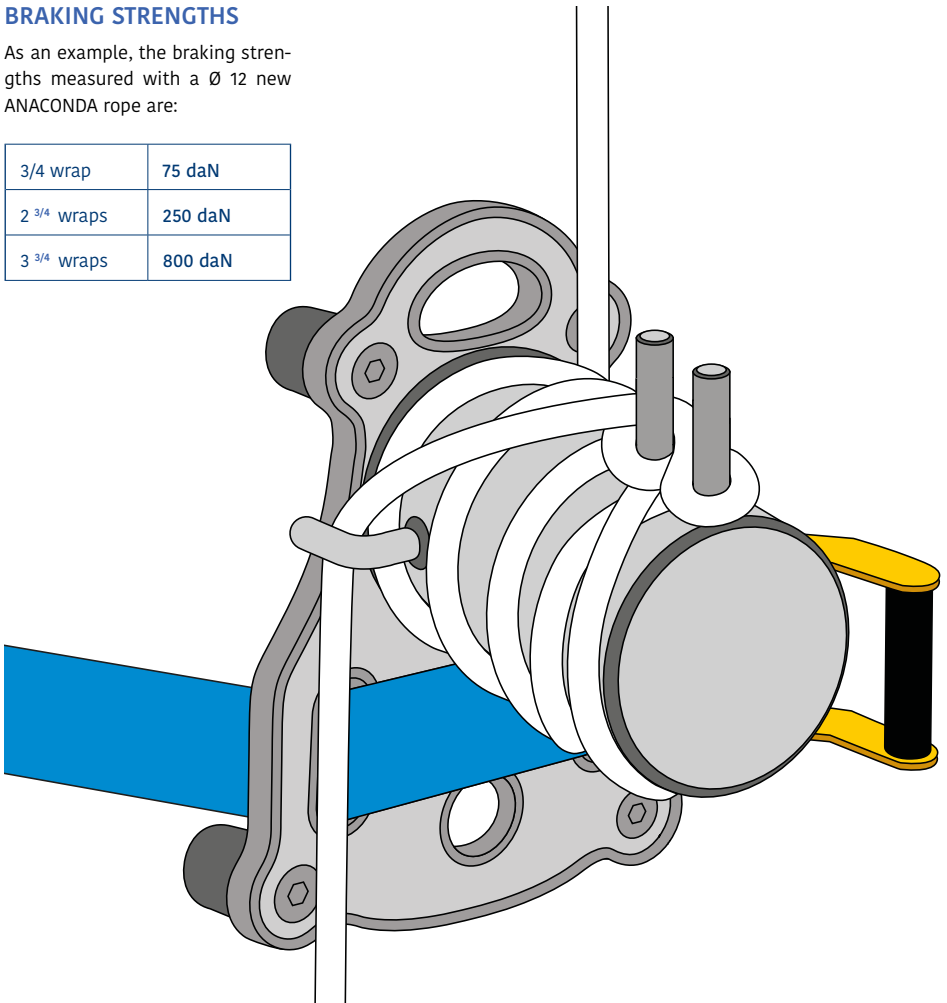

These braking strengths are given as reference only. Please note that they can vary according to: braiding, wear, the cleanliness of the ropes used, and environmental conditions.

6.8 • USE OF THE UPPER RING

The half-oval hole on the base plate is a comfort accessory. It serves to attach systems to tighten the rigging rope or pull the load while in rigging position. Loads can then be pulled taut or moved up, to be lowered using the friction from the cylinder as described above.

It is also used to help set it up with the CROCH'TY strap.

6.9 • PULLING THROUGH REEVING OF THE RIGGING ROPE

A Pulling using single reeving of rigging rope (simple pulley, mechanical adjuster, connectors)

- Put the rope in maximum braking position, secure it (see illustration chapter 6.7).
- Place the mechanical adjuster (or knot) on the rigging rope, add a simple pulley to the mechanical adjuster, pass the rigging rope slack through the pulley.
- Pull hard.
- To lower the load:
 - Secure the rigging rope on the cylinder (see illustration chapter 6.7).
 - Remove the mechanical adjuster and the pulley.
 - Lower the load by letting the rigging rope slip around the cylinder.

B Pulling using double reeving of rigging rope (simple pulley, double pulley, mechanical adjuster, connectors)

- Put the rope in maximum braking position, secure it (see illustration chapter 6.7).
- Place a mechanical adjuster on the rigging rope (or knot), attach the double pulley to the mechanical adjuster and the simple pulley to the half-oval hole up the plate.
- Pass the rigging rope slack through the double pulley and then through the simple pulley and pass it back through the double pulley.
- Pull hard.
- To lower the load:
 - Secure the rigging rope on the cylinder (see illustration chapter 6.7).
 - Remove the mechanical adjuster and the pulleys.
 - Lower the load by letting the rigging rope slip around the cylinder.

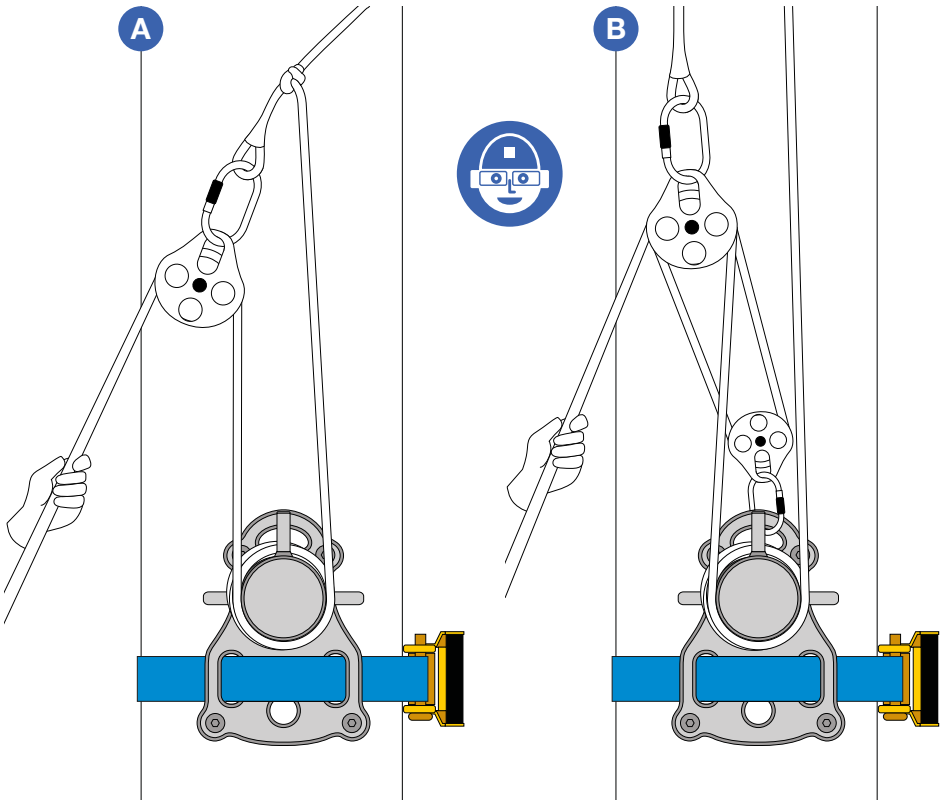

6.10 • USER POSITION DURING LOWERING

When lowering, never stand under the load. Wear gloves when working with rope so as not to burn your hands. In order to avoid catching fingers or hands, the user must stand away from the cylinder to let the rope slide around it. The rope must be held with two hands, the slack properly positioned, without knots or tangled branches. Never wrap the rope around user's body or hand. It must be to one side of the operator, held with both hands.

6.11 • STATIC BRAKING

This solution while working only applies to loads located below the pulley anchoring point. Static braking consists of making the friction system taut ahead of time. This way, the cut branch or log does not produce any shocks and the friction system and its components remain intact.

6.12 • DYNAMIC LOWERING

This solution is applied in the following two cases:

1 Mandatory for loads located above the pulley anchoring point:

when the logs or the crowns found above the pulley are cut, they fall and then are retained.

If the rigging rope is blocked on the cylinder (too many wraps or the user is holding tightly), an important shock will be produced in the braking system and breaking or damage to the equipment and the tree are inevitable:



WARNING! 100 kg falling from 1 metre = approx. 600 daN of shock force

It will be necessary to absorb the shock. To do this: Let the load slide down and brake it gradually. The cut log falls and the system becomes taut, the rigging rope slips around the cylinder, the user gradually slows the log fall and stops it. Only this procedure ensures absorption of the shock produced by the log.

2 Optional for loads located under the pulley:

To secure the climber, the branches located under the pulley can slip down quickly after they are cut and can be stopped using the dynamic braking (as explained in 1): The rope is tight but not blocked. The branch is cut, it falls and the rigging rope slips around the cylinder. The user gradually slows the fall and stops it.

7 SYMBOLS AND LABEL

The presence of symbol labels on the device is mandatory.

If they deteriorate or disappear, replace them. You can order them from your vendor.

Label on the front of the cylinder.

These numbers are also stamped on the rim of the base plate.

Brand

Type

Year

CE
Conformity

MBS

Name

Serial number

Manufacturer's
address

Working
Load Limit (WLL)

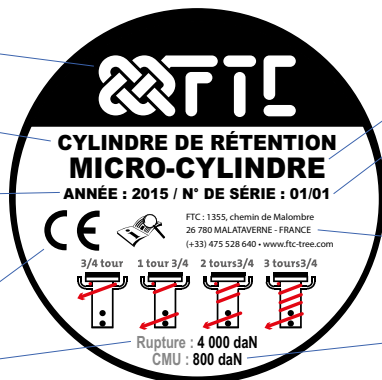

COMPLIES WITH THE  DIRECTIVE**NEW DEVICE SUBJECT TO SELF-CERTIFICATION**

Manufacturer: FTC : 1355, chemin de Malombre • Z.I. Les Plaines
26780 MALATAVERNE • FRANCE • (+33) 475 528 640
contact@ftc-tree.com • www.ftc-tree.com

Registration number (SIRET) 812 605 061 000 25

Declares that the new equipment indicated below:

Type MICRO-CYLINDRE

Serial number

Manufacturing date

Working Load capacity (WLL): CMU : 800 daN

Complies with the conditions in the revised Machinery Directive (2006/42/ )
and the national legislation transposing it.
Complies with the dispositions defined by the revised decrees no. 92-765, 92-766, 92-767 of July 29, 1992.

Application of  marking on the listed equipment.
The technical documents for commissioning, maintenance and use are delivered with the devices.

Signature of company representative: Laurent PIERRON, Director

Signed in MALATAVERNE, 27/07/2017





PLAY WITH GRAVITY

1355, chemin de Malombre • Z.I. Les Plaines

26780 MALATAVERNE • FRANCE • (+33) 475 528 640

contact@ftc-tree.com • **www.ftc-tree.com**